

CERTIFIED PRODUCTS DIRECTORY

SEALED INSULATING GLASS

PHONE (315) 646-2234

February 2023



#0961

ISO/IEC 17065

Product Certification Body

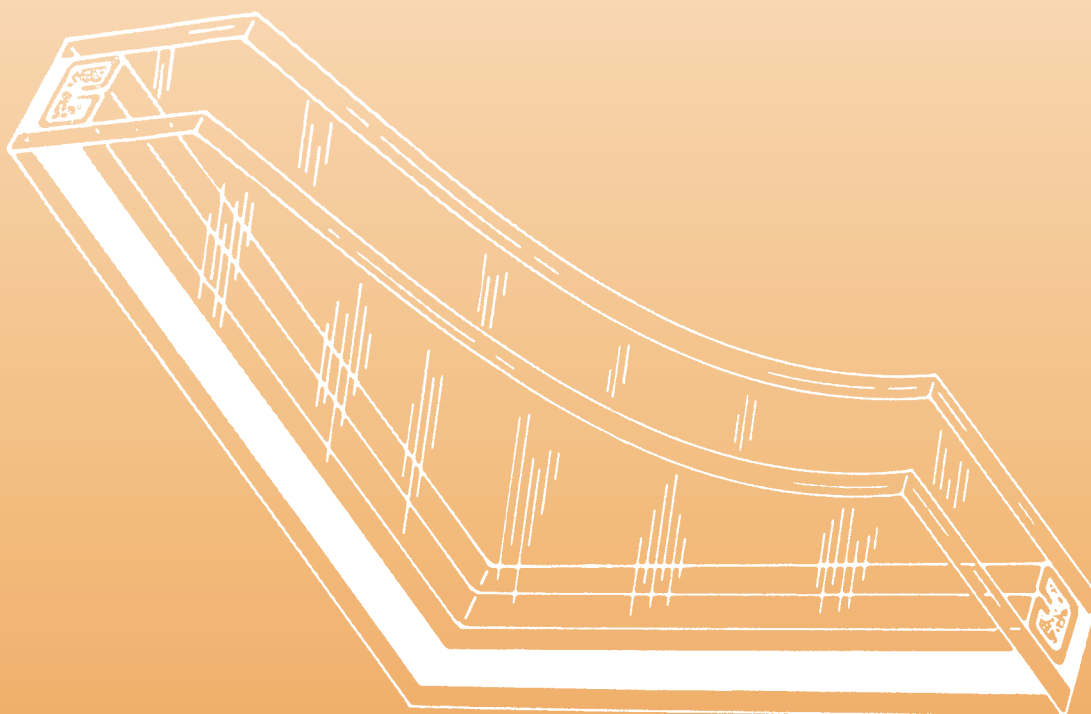

IGCC® and IGMA® Certification programs have been combined into a single certification program designated IGCC®/IGMA®. IGCC® will license the use of the IGMA® trademark and direct certification with IGMA® support.

INSULATING GLASS

IGCC®

CERTIFICATION COUNCIL

IGMA

INSULATING
GLASS
MANUFACTURERS
ALLIANCE

CREDIBILITY IN INDUSTRY CERTIFICATION THROUGH ACTIVE PUBLIC PARTICIPATION

Visit Our Website @ WWW.IGCC.ORG

IGCC® 2023 Spring Certification Committee Meeting

May 2-3, 2023



Embassy Suites by Hilton

San Antonio Riverwalk Downtown
125 E Houston St.
San Antonio, TX 78205

Book your reservation here:

Online: <https://www.hilton.com>

By Phone: 1-800-362-2779

Ask for the "IGCC" Group Rate "90D"

IGCC Meeting Schedule

Monday, May 1, 2023

6:30 – 8:30 Board of Governors Dinner – TBD (Board Members Only)

Tuesday, May 2, 2023

8:00 - 8:30 Breakfast for Board of Governors (Board members only)
8:30 - 12:00 IGCC® Board of Governors Meeting and lunch (Board members only)
1:00 - 5:00 IGCC® Certification Committee Meeting
5:00 - 5:15 Participants Meeting
6:00 - 7:00 Reception for Meeting Attendees & Guests

Wednesday, May 3, 2023

6:30 - 7:30 Complimentary Hotel Breakfast for all Guests served in Breakfast/Atrium Area
8:00 - 11:30 IGCC® Certification Committee Meeting
12:00 - 1:00 IGCC® Board of Governors Meeting and lunch (Board Members Only)

Reservations

Hotel Reservations can be made [online](#) or by calling 1-800-362-2779. The room rate is \$229 per night plus taxes. Please reference the "IGCC" Group "90D" if calling in your reservation.

Hotel reservations for the meeting must be made before April 10th, 2023.

Please Note: The hotel is 9 miles from the San Antonio International Airport. Shuttle to and from the airport is **NOT** available. Uber/Lyft are available from the airport to the hotel.

Please notify the IGCC office of your intent to attend this event. If you have any questions or difficulties, please contact igcc@amscert.com or 315-646-2234.

TABLE OF CONTENTS

IGCC® Program Concept	2
Accreditation	4
IGCC® Board of Governors	5
Certification Committee	6
Communications	11
Participants	12
Past IGCC® Presidents' Recognition	13
Meetings of the Certification Committee	13
Certified Products Key	14
Certified Products (Alphabetically By Plant)	15
Prototypes in Progress	62
Procedural Guide	64
IGCC®/IGMA® Label Requirements	70
Advertising Guidelines	72
Quality Assurance Program	73
Gas Content Initial & After Weathering Certification & Testing (GCIA)	74
Component Validation	75
Guidelines & Interpretations	75
Guidelines: Always	76
Guidelines: Never	79
Internal Components	81
G.16 Failure to Comply	88
Specifications Used	90
Participant's Agreement	91
License Agreement	94
IGCC®/IGMA® Approved Laboratories	100

Certification information and guidelines are included in the twice per year printing of the Certified Products Directory or are available from IGCC® upon request. Re-printing of this information in any other manual, material or document without the written permission of IGCC® is in conflict with the desire of IGCC® and should not be interpreted as being endorsed by or affiliated with IGCC®.

By Insulating Glass Certification Council, Copyright © 2023 - All Rights Reserved

IGCC®/IGMA® PROGRAM

The IGCC®/IGMA® Certification Program is the product of the effort to harmonize the legacy IGCC® and IGMA® certification programs. After several years of reviewing the two former certification processes, best practices were identified and on February 3rd, 2009 an agreement was signed where IGCC® shall license the use of the IGMA® certification mark in the administration of a single combined program known as IGCC®/IGMA®. The single program will operate under one set of requirements and guidelines and allow former participants in either IGCC® or IGMA® certification to label with IGCC®/IGMA® thus enjoying the greater recognition of both marks. IGCC® shall administer and govern the IGCC®/IGMA® program on behalf of IGMA® and IGCC® in accordance with the program requirements as set forth in the IGCC®/IGMA® Certified Products Directory and Procedural Guide.

The IGCC® Board of Governors is responsible, pursuant to the IGCC® Corporate Bylaws, for all corporate decisions concerning certification of products under the IGCC®/IGMA® Certification Program. The IGCC® Board will at all times be composed of individuals representing the public interest and individuals representing the insulating glass industry in equal proportion.

IGMA® may make recommendations to the IGCC® Board regarding the IGCC®/IGMA® Certification Program and may appeal any decision of the IGCC® regarding certification or the IGCC®/IGMA® Certification Program.

IGCC® PROGRAM CONCEPT

Manufacturers of sealed insulating glass units, consumers, specifiers, and others who are responsible for or concerned with the quality and performance of products purchased in the public interest, recognizing a need for a sound product testing and performance certification program, have jointly established the Insulating Glass Certification Council (IGCC®). Founded in 1977, all IGCC® meetings are open to the public and public participation is encouraged.

IGCC® is a non-profit organization which sponsors and directs a program of periodic accelerated laboratory testing and plant audits to ensure continuing product performance through specified standards. The testing specifications used are outlined in "ASTM Specification E2190 for Sealed Insulating Glass." It is the policy of IGCC® to remain flexible in referencing specifications and test methods in order to best reflect changing technology and new developments.

IGCC®'s responsibilities through its administrator are to see that periodic audits and independent laboratory tests are performed on participating manufacturers' products and to validate the right of that manufacturer to use the IGCC® label on the product or products information claims. Additionally, IGCC® requires licensees to have a working quality assurance program for the fabrication of insulating glass. Adherence is verified during plant visits conducted twice per year. These requirements were adopted to improve the overall quality of IG units in the program, and to satisfy requirements established by the Department of Housing and Urban Development, HUD.

Management and control of the program is vested in a Board of Governors made up equally of industry and public interest members. The public interest representatives are empowered with 50 percent of the voting power to ensure against undue industry influence of IGCC® action.

The program is under the supervision of a qualified administrator who is not affiliated with any manufacturer of insulating glass, material supplier, or participating testing laboratory, and is hired by and responsible to the Insulating Glass Certification Council. The manufacturers of the products listed herein have certified that the labeled materials comply with the performance characteristics established by ASTM E2190. The compliance of the manufacturers with the requirements of that specification is validated periodically by the IGCC® administrator through audits and testing by an independent testing laboratory under the administrators' direction.

Every manufacturer of insulating glass is eligible and encouraged to apply for the right to use the IGCC® label. However, permission to use the label is not granted until an independent laboratory test verifies compliance with the requirements. Once all requirements have been met, each product is assigned an IGCC® number to identify the product, performance class, and the factory in which it is made. Throughout the year, IGCC® requires the manufacturer to certify that the labels are being used only on units that are produced in the same manner and with the same materials as the tested specimens. Based upon these declarations, IGCC® authorizes continued use of the IGCC® label and the product listing published in this directory.

The Insulating Glass Certification Council wishes to recognize the substantial contributions made by the Safety Glazing Certification Council, the Sealed Insulating Glass Manufacturers Association (SIGMA) (now known as IGMA), American Society for Testing and Materials (ASTM), National Institute of Standards & Technology (NIST), FHA, HUD, Public Interest Persons, the Industry, and particularly consumers. Without input from such a broad cross-section, this program would not be possible.

IGMA®

The Insulating Glass Manufacturers Alliance is a North American association of insulating glass manufacturers, suppliers of component materials and other industry related professionals dedicated to upgrading product / service performance by promoting awareness of technological developments in the industry. IGMA® provides the leadership required to assure the continued growth of the Insulating Glass Industry.

IGMA® was formed as the result of the merger of IGMAC (Insulating Glass Manufacturers Association of Canada) and SIGMA (Sealed Insulating Glass Manufacturers Association) in October of 2000 to establish and advance insulating glass technologies and quality processes in order to create a standard of excellence that provides value to the insulating glass industry. As part of its mission, IGMA developed a voluntary certification program for insulating glass units.

The IGMA® Certification Program recognized the need for regular and impartial product testing, maintenance of quality control in the manufacturing process and identification of products that conform to these criteria. Manufacturers of insulating glass units were invited and encouraged to participate in the IGMA® Certification Program.

ACCREDITATION

In 2014 the American National Standards Institute (ANSI) issued ISO/IEC 17065 Accreditation to the IGCC®/IGMA® Certification Program and AMS, Inc., the program Administrator and Certification Body (CB). This Accreditation is a formal recognition of fulfilling the requirements of the ISO/IEC 17065:2012 standard, as well as ANSI's own accreditation requirements.

What is Accreditation?

Accreditation is similar to certification. Just like in certification there is an independent party who assesses and determines whether or not an organization meets specific requirements. In the case of ANSI's assessment of the IGCC®/IGMA® Certification Program and AMS, Inc., they were assessed to ISO standard ISO/IEC 17065:2012. The end result is called accreditation.

Who is ANSI?

The American National Standards Institute is a not-for-profit entity providing assessment and accreditation of bodies performing third-party conformity assessment (certification), among other services. ANSI also brings global recognition to conformity assessment through several international and regional arrangements for multi-lateral recognition, including the International Accreditation Forum (IAF). In addition, ANSI has a memorandum of understanding (MoU) with the Standards Council of Canada (SCC). All of this helps bring global acknowledgement to conformity assessment.

Information from: *ansica.org*, Why Seek Accreditation?, 2015. Web. August 19, 2015.

What is ISO/IEC 17065:2012?

ISO/IEC 17065:2012 is an internationally recognized standard for bodies certifying products, processes, and services. It is the main source of criteria used to assess the IGCC®/IGMA® Certification Program and AMS, Inc. The standard specifies requirements that, according to ISO/IEC 17065:2012, "ensure that certification bodies operate certification programs in a competent, consistent and impartial manner...".

How will this affect a Fabricator's IGCC®/IGMA® Certification?

Accreditation of the IGCC®/IGMA® Certification Program and AMS, Inc. is the formal recognition that they have met strict requirements placed on them. This means that as a fabricator, operator, or provider of certified products, you can be sure that the IGCC®/IGMA® Certification Program is operated to some of the highest quality standards in the world. Because the IGCC®/IGMA® Certification Program and AMS, Inc. have always followed stringent guidelines there will be minimal changes to the certification program. When changes are necessary though, you will be notified in advance.

Though the IGCC®/IGMA® Certification Program requirements won't change much due to the accreditation, it does offer an opportunity for fabricators to show conformance to an ANSI-Accredited certification program, an invaluable association to set you apart in the market. For more information, and restrictions and limitations, please contact AMS, Inc.

Disclaimers

While there are significant benefits to being associated with this accreditation, accreditation doesn't mean that ANSI approves certified products, processes, or services of fabricators. In addition, the ANSI Accreditation symbol and ANSI logo are not permitted to be displayed on any product or its packaging.

Questions or Want to Learn More?

If you have any questions or need additional information regarding any of the topics presented above, please feel free to contact AMS, Inc. at (315) 646-2234, or email us at igcc@amscert.com

February 2023
IGCC® BOARD OF GOVERNORS

REPRESENTING PUBLIC INTEREST

Elaine Rodman
Homeowners Association
2300 Sample Road
Allison Park, PA 15101
Telephone: (412) 487-2887
E-mail: elainesrodman@gmail.com

Yvon Chiasson
Morrison Hershfield Limited
175-1005 Skyview Drive
Burlington, ON L7P 51 CANADA
Telephone: (905) 483-1012
E-mail: YChiasson@morrisonhershfield.com

Dennis Johnson
Raths, Raths & Johnson
500 Joliet Road, Suite 200
Willowbrook, IL 60527
Telephone: (630) 325-6160
E-mail: dkjohnson@rrj.com

Bruce Kaskel
Wiiss, Janney, Elstner Associates, Inc.
10 South LaSalle Street, Suite 2600
Chicago, IL 60603
Telephone: (312) 372-0555
E-Mail: bkaskel@wje.com

Max Wolf
Skidmore, Owings & Merrill
7 World Trade Center
250 Greenwich Street
New York, NY 10007
Telephone: (212) 398-9300
Email: Max.wolf@som.com

REPRESENTING INDUSTRY

Michelle Phan
Cardinal
1300 SW 44th Avenue
Ocala, FL 34474
Telephone: (352) 291-6896
E-mail: mphan@cardinalcorp.com

Todd Schauder
ODL, Inc.
215 E. Roosevelt Avenue
Zeeland, MI 49464
Telephone: (540) 664-5499
E-mail: todd.schauder@odl.com

Joe Erb
Quanex
800 Cochran Avenue
Cambridge, OH 43725
Telephone: (740) 439-2338
Email: joe.erb@quanex.com

William Davis
Vitro Flat Glass, LLC
400 Park Drive
Carlisle, PA 17013
Telephone: (412) 820-8044
E-mail: wdavis@vitro.com

Adina Dobre
Intigral
7850 Northfield Rd
Walton Hills, OH 44146
Telephone: (216) 385-7810
Email: adina.dobre@intigral.com

IGCC® OFFICERS

Dennis Johnson, President
Todd Schauder, Vice President, Treasurer
Michelle Phan, Secretary

IGCC® CERTIFICATION COMMITTEE

Joe Erb, Chairman

Membership and voting privileges on the IGCC® Certification Committee shall be extended to (a) each IGCC® Public Interest Governor (b) each IGCC® Business Community Governor (c) each IGCC® or IGMA® participant supplier (d) Public Interest representatives appointed by IGMA® and IGCC® Boards, and (e) each IGCC®/IGMA® participant Licensee who designates a representative to serve on the Certification Committee (listed below).

<u>Licensee</u>	<u>Primary Member</u>	<u>First Alternate</u>	<u>Second Alternate</u>
A.N. ALODAN & SONS CO. GLASS & ALUMINIUM FACTORY	Dhanraj Singh Parmar	Rakesh Kumar Pal	
AAG-AI Abbar Architectural Glass	Mohammad Asif Ali	Russell Platon	
Advanced Impact Technologies	Ralph Henson	David Daley	
Advantage Glass Corp	Stan Rydzewski	Rony Gramajo	
AGC Flat Glass (Thailand) PLC.	Tharatorn Tantirak		
AGNORA LTD	Rene Govers	Brent Stannard	
Al Andalus Glass Factory Co.	Eng. Amir Abdullatif	Eng. Ahmed Arafa	
Aldora Aluminum and Glass Products, Inc.	Manny Valladares	Bill Demato	Brian Crimmins
All Counties Glass Distributors	Dane Treiber	Jay Menjarez	
All Weather Windows	Thuy Vu	Cory Diepenbeck	Robert Giles
Aluminum Technology Auxiliary Industries	Varun C.R.	Suraj Thampi	
American Glass	Aaron Day	Steve Tatum	
American Insulated Glass LLC.	Billy Blair	Shane Ellerbee	Eddy Green
Andersen Corporation	Nicholas Zeman	Drew Pavlacky	
AntCam Cam Pazarlama San. Ve Tic. A.S.	Yasemin Budak	Firat Meteoglu	
Architectural Glass Products, LLC.	Sharon Gambill	Andy Zuniga	
Arino Duglass, S.A.	Raimundo Garcia-Figueras	Miguel Mateo	
AROW Global Corporate	Randy Aguilar		
Associated Materials, Inc.	Seth Green	Steve Harp	
Astiglass S.L.	Inmaculada Jimenez		
Beijing Haiyangshunda Northtech Glass Ltd.	Kun Wang	Sunny Zhang	
Beijing Wuhuatianbao Glass Co., Ltd.	Nan Zheng Bo		
Blue Star Glass Inc.	Alex Oanono		
Builders First Source	Jay Looney		
BVGLAZING SYSTEMS	Jed McKie	Andrew Dolphin	
Camyapi Cam Paz. Ins. Taah. Tic.ve San. Ltd. Sti	Volkan Erem	Yüksel Arslan	
Cardinal IG	Michelle Phan	Robert Grommesh	
Carey Glass UC	Michael Carew	Liam Gillespie	
Cascade Windows Inc.	Dylan McGuire		
Central Valley Glass & Screen, Inc.	Geoff Smith		
Changshu High-Tech Energy-Saving Dorwin Co., Ltd.	Fa Zhenju		
ChangShu Maybo Glass Co., Ltd.	Qian Lan		
Changshu Sysen Glass Products Co., Ltd.	Xia Jian		
Changshu Weier Glass Products Co. Ltd.	Denise Lu		
Changshu ZhongCheng Building Materials Co., Ltd.	Rachel Chen	Mr. Yu Wei	
Changshu Zhongqin Building Material Co., Ltd	Mona Xu		
Changxing Kibing Energy Saving Glass Co., Ltd.	Zhang Xiaojun		
Chin Ta Glass Co., Ltd.	Hung Jui-Ting	Chen Yun-Ju	
Ching Chyau Co., Ltd.	Tony Chang	Chen Zhiwei	
Chongqing SYP Engineering Glass Co., Ltd.	Sun Dahai		
Ciraylar Cam Insaat Malzemeleri San. VE TIC. A.S.	Mehmet Emre Aslan		
Clear Lite DBA Innovative Glass Products LLC	Tim Valek		
Cmech Ltd.	Justin Char		
Comercial Dialum SA	Maria Jesus Encina	Rose Marie Bastias	
Complete Line Glass Wholesalers, Inc.	Kyle Russell	Chris McCumber	
Consolidated Glass and Mirror, LLC	Mike Frazier	Doug Osborne	

February 2023

<u>Licensee</u>	<u>Primary Member</u>	<u>First Alternate</u>	<u>Second Alternate</u>
Cristacurva	Claudia Valencia		
CS ECO Glass (M) Sdn Bhd	Zhang Xiaojun		
Custom Glass Prod. Of Carolina	Steven Reeder	Tony Klutz	
Custom Glass Products Inc.	Eric Reeder	Jim Wocelka	
Diamond Glass	Darren Nevin		
DongGuan CSG Architectural Glass Co., Ltd.	Su Jingxi		
DongGuan Longlass Fire Resistant Technology Co., Ltd.	Dizun Zhuang		
Donguan Ngai Wah Bending Tempering Glass Company Limited	Yang Shengyong	Kevin Reinthaler	
ECO Glass Production	Samuel Bravo		
EFCO Corporation	Doug Bishop		
Eivate America Corporation	Ana Gabriela Assemat Moreno	Fransue Morales-Martinez	
Emirates Glass L.L.C.	Sandeep Nair		
Engineered Glass Products, L.L.C.	David Colombe	Dennis Carroll	
Erdem Dis Ticaret A.S.	Tuncay Güven	Yavuz Selim Bodur	
Fairis C.A.	Jorge Jaramillo	Moises Flores	
FAKRO GP Sp. Z.0.0.	Pawel Szewczyk		
Fenplast, Inc.	Benoit Pepin	Manon Lemieux	
FG Glass Industries Pvt Ltd.	Tariq Kachwala		
Flat Glass Distributors, Inc.	Doug Lewis		
Flat Glass Group Co., Ltd.	David Wei	Li Chunpeng	
Foshan Super Glass Industrial Company Limited	Ban Naimao		
Future Architectural Glass LLC	Shankar Ganesh	Soihail Kachwala	
General Glass	Kristy Hackworth		
Gentek Building Products Ltd. Partnership	Christian Cirino	Seth Green	
GLAAM Co., Ltd.	Eunyoung Han	Jaeyoung Choi	
GLASPRO	Ed Lemley	John Griffin	
Glass and Mirror Craft	Steve Gizicki	Patrick McEvoy	
Glass Enterprises Inc.	Mr. Josh Burg		
Glass Insulators Inc.	Stacy Marik		
Glassbel Baltic JSC	Romas Zvirzdinas		
GlassFab Tempering Services, Inc.	Robert Gardner Black		
Glassforms LLC	Semaan Semaan		
Glasstech Industries B.S.C.	Marwan Khadij	Hem Raj Arya	
Glasswerks LA, Inc.	Robert Mastrapa		
Glaz-Tech Industries, Inc.	Alex Miramomtez		
Glenny Glass Co.	Chris Hawkins	Doug Bain	
Global Security Glazing	Scott Reynolds	Mark Johnson	
GnT Glass Co., Ltd.	Hao Bing Tian		
Greaney Glass Products Ltd	Ronan Greaney	Paul Connaughton	
Great Day Improvements, LLC	Kent Nusser	Craig Cox	
Grupo Vidrios el Castillo	Carlos Benet Trad	Gabriel Howerton	
G-TECH Optoelectronics Corporation	Channing Lafite		
Guang Dong Kibing Energy Saving Glass Co., LTD	Liao Shanshun		
Guangdong Haikong Special Glass Technology Co., Ltd.	Liu Fan	Sven Pan	
Guangdong South Star Glass Limited	Taylor Lee		
Gulf Glass Industries, Co. LTD	Pascoal Dsilva		
Hankuk Glass Industries, Inc.	Kyungwan Kang		
Haojing Holdings Group Limited	Wong Xiang Yang		
Hartung Glass Industries	Tim Kroha	Peter Shoenfeld	
Harvey Building Products	Dave Lambert		
Insulite Glass Co., Inc.	Larry Vasholz		
Interpane Glasgesellschaft, mbH - Plattling	Luis Hidalgo		
Intigral	Mark Hutchinson	Adina Dobre	
Isam M. Khairi Kabbani Glass Works LLC	Donald Cardenas	Roy Bassil	Mustafa Bokhari

<u>Licensee</u>	<u>Primary Member</u>	<u>First Alternate</u>	<u>Second Alternate</u>
Isoclima Specialty Glass, LLC	Chris Cotton		
ITI Glass Company	David Wickham	Rick Law	
Jasan Glass - JSG	Kyungsoo Lee		
Jiangmen Junfa Safety Glass Co., Ltd.	Xiaodan Li		
Jingmei Curtain Wall Technology Co., Ltd.	Mr. Feng Fanran		
Jinzhou Fortune Spring Glass Co., Ltd.	Grace Liu		
Jiuh Sheng Glass Co., Ltd.	Arthur Hung		
La Tecnica Nel Vetro SpA	Robert Sammarco		
Laurier Architectural, Inc.	Melanie Mercier	David Levesque	
LTI Smart Glass, Inc.	Bill Baumann	Donnie Miller	
M Industria S.A. DE C.V.	Mauricio Millet Median	Ricardo Tonueyo	Mex Yucatan
Mannix Exterior Wall Systems, Inc.	Paul Greenstein		
Maryland Glass & Mirror	Ashton Bird		
Megaluminio Servicios S. A. de C.V. DBA Megaglass	Fernando Lovera Colin	Luis Angel Sebastian Mateo	
Mid-American Glass, Inc.	Michelle Magyar		
Midwest Glass Fabricators Inc.	Armando DeSenzio	Cory Duso	
Nashville Tempered Glass Corp.	Phillip Contella	Jon Johnson	
Northwestern Glass Fab	Eric Fortin	Chris Streefer	
Northwestern Industries, Inc- Yuma, AZ	John Butler		
Novatech Canada Inc.	Erick Giroux	Eric Lessard	
Novatech Patio Doors Ontario Inc.	Claudio Sacilotto		
Novavetro S.r.l.	Cristiano Lucentini	Giuliano Toniolo	
ODL, Changshu ZhongXin Building Materials Co., Ltd.	Todd Schauder		
ODL, Inc.	Todd Schauder		
Oldcastle BuildingEnvelope®	Rick Wright	James Jensen	
Opulux Glass	Donavan Soproni		
PA Glass Inc.	Hui Lin		
Panjin Truspacer Insulating Glass Material Co., Ltd.	Rao Desong		
Pella Corporation	Matt Waldren	Chris Chandler	
Perficom S.A. DE C.V.	Miguel Angel Robles Lopez		
PFG Glass Industries	Ryan Nielsen		
Philly Glass Industry Inc.	Felix Wu		
Pilkington IGP Sp. z.o.o. Branch Skierniewice, Poland	Krzysztof Skarbinski		
Pioneer Window Mfg. Corp.	Eric Miller		
Piva Group North America LLC	Fred Haislet		
Precision Glass Industries	Abdeali Karimjee		
Prelco Inc.	Christian Lizotte		
Prelco MTL Inc.	Christian Lizotte		
PRESS GLASS d.o.o	Robert Mokwa	Milosz Majewski	
PRESS GLASS SP ZOO	Milosz Majewski		
Press Glass, Inc.	Adrian Weźgowiec		
PRL Glass Systems	David Landeros		
Productora y Distribuidora de Espejos S.A. de C.V.	Jose Natividad Gonzalez	Andres Gonzalez	
ProTemp Glass, Inc.	Paul Ferguson		
Pulp Studio, Inc.	Oscar Ramirez		
Qingdao Kingdom Glass Co., Ltd.	Luo Qiuliang		
Qinhuangdao High Tech Energy Saving Dorwin Co., Ltd.	Sherry Shi	Su Chang	
Qinhuangdao Qicaishi Glass Processing Co., Ltd.	Cindy Sun	Chen Qifei	
Qinhuangdao Qinsheng Glass Products Co., Ltd	Cai Zhiping	Dong Xiaoguang	
Qinhuangdao Rongsheng Glass Processing Co., Ltd.	Dongsheng Yan		
Qinhuangdao Shucheng Energy Saving Technology Co., Ltd	Zheng Lin		
Qinhuangdao Xinhua Glass Processing Ind. Co. Ltd.	Feng Jianqiao	Lucy Liu	
Qinhuangdao Zhenhong Door and Window Co., Ltd.	Yang Qi		

<u>Licensee</u>	<u>Primary Member</u>	<u>First Alternate</u>	<u>Second Alternate</u>
Quest USA, Inc.	Joe Kuykendall	Robert Farris	
Quest Window Systems	Jody Cash	Daniel Zalzman	
R&R Insulated Glass Products D.B.A. Aurora Windows and Doors	Ery Hernandez	Claudia Pardo	
Reem Emirates Aluminum & Glass	Hamed Hussein		
Reflex d.o.o.	Rudi Hajdinjak	Bostjan Kous	
SAAND Inc.	Frank Santangelo		
SAGE Electrochromics Inc.	Benjamin Trembl		
Saint-Gobain India Private Limited	Uprenda K.		
Saudi American Glass Company	Liberto Gubat		
Seretti SRL	Vigutto Stefano		
ShanDong HaanGlas Co., LTD	Han Xiao Qing	Zhang Yong Jian	
Shandong Jinjing Science & Technology Stock Co., Ltd. Boshan Branch.	Boyan Zhai		
Shandong Yaohua Glass Co., Ltd.	James Hu		
Shanghai Lead Glass Co., Ltd.	Xu Wei		
Shanghai Yaohua Pilkington Glass Group Co., Ltd.	Dr. Sun Da Hai	Wang Genjie	
Shenbo Special Architectural Glass Industrial Co., LTD	Elena Tang		
Shenng Mwuh Enterprise Co., Ltd	Cai Zhihong		
ShenZhen LiaoYuan Glass Co., Ltd.	Xuanmin Fu		
Shenzhen Shennanyi Glass Product Co., Ltd	Sophie Lee	Yellow Shi	
Shine Glass Co., Ltd.	Liang Yuxuan		
Shinn Fu Pair Glass Co.	Huang Hsin Fu		
Sichuan CSG Energy Conservation Glass Co., Ltd.	Liu Song		
Sierra Glass Fabrication Inc.	Mike Fedyk	Justin King	
Sierra Pacific Windows	Rick Audsley	Cheryl Wibben	
SIGCO, Inc.	Matthew Dunn		
Skyland Insulated Glass Corp.	Ricky Zeng		
Soluciones Vitro Plano S.A. de C.V.	Alberto Vilchis Trujillo		
Standard Building Products, Inc.	Candy Qin		
Stanley Glass Co., Ltd.	Tony Hsu		
Stargrup Cam A.S.	Ali Nurman		
Strong Tempering Glass Industry LLC	Mark Chen		
Sunglas Technics Co., Ltd.	Jianxin Zhao		
Suzhou Taifeng Glass Decoration Co. Ltd	Lily Ye		
Syracuse Glass Company, LLC	Joe Gudenburr		
Tai Shan City Da Heng Art Glass Ltd.	Liu Wogui		
Taiwan Glass USA Sales Corp.	Albert Wang		
Technical Glass & Aluminum Co. L.L.C.	Giri Sanker	Ali Hajj Hassan	
Tecnoglass S.A.S.	Diana Lohrer		
Tecnovidrio S.A. de C.V.	Sara Ivonne Penaloza		
Temp Glass Inc.	Sigfridio Martinez	Marcela Bolivar	
Tempco Glass and Fabrication, LLC	Kent He	Tiffany Wan	
Templados Del Centro SA DE C.V.	Victoria Nunez		
Templados Industriales S.A. de C.V.	Diana Gonzalez	Pedro Chavez	
TG Tianjin Glass Co., LTD	Zhengyue Wang	Jing Zhang	
Thermafex A.J. Inc.	Frederic Fillion	Francious Ouelette	
Thermo BSL	Pierre-Luc Bellavance	Claude Pelletier	Guy Poirier
Thompson I.G. , LLC.	Cameron Alford	Dale Houck	
Tianjin CSG Energy Conservation Glass Co., LTD	Honglei Dai		
Tianjin Northglass Industrial Technical Co., Ltd.	Hu Zhangyan		
Tower Insulating Glass LLC.	Barry Litt		
Tristar Glass, Inc.	Doug Vail		
Trulite Glass and Aluminum Solutions	Jeff Haberer		
TSY-Fong Glass, Co., Ltd.	Hanss Huang		
TVITEC System Glass, S.L.	David Lopez	Pablo Alvarez Menendez	

February 2023

<u>Licensee</u>	<u>Primary Member</u>	<u>First Alternate</u>	<u>Second Alternate</u>
Unicel Architectural Corp.	Vincent Couturier		
Uniglass	Fahad Al Fozan	Mohammed Haneef	
Union Glass s.r.l.	Franco Savian		
United Plate Glass Co., Inc.	George Tesnovich	Matt Anderson	
Unitex Glass Chengdu Co., Ltd	Andy Yu	Chen Xinhua	
Val y Val SA de CV	Jorge Aviles		
Valda 90 Ltd.	Velco Burov	Hristo Vasilev	
vandaglas Eckelt GmbH	Guillaum Kaminski		
VELUX America LLC	Mike Rhoden	Mike Dorn	
Vetrodomus SpA	Federico Casaccio	Chiara Pastore	
View Inc.	Derek Parker		
Viewmax Windows and Doors, Ltd.	Lu Houchang		
Vinyl Window Designs Ltd.	Kaz Feret	Matthew Spatafora	
Viracon Inc.	Michael Schettler	Mike Nelson	
Vitelsa Mosquera S.A.	John Lopez		
VITROTERM-MUROW S.A.	Krzysztof Kolodziejczyk		
Vitrum Industries Ltd.	Jagdeep Singh		
W. A. Wilson Inc.	Rick Meredith	Robert Hartong	
W.C.P., Inc dba West Coast Insulated Glass Products	Rusty Neubauer		
Westeck Windows Mfg. Inc.	Mike Davidson		
White Aluminium Enterprises L.L.C	Jabr Doshan		
Wholesale Glass Distributors, Inc.	Robert Contreras		
WHTB Glass, LLC	Yufeng Peter Pan	Alan Tan	
Windsor Windows and Doors	Mark Mckenzie		
Wujiang CSG Huadong Architectural Glass Co., LTD	Yu Jinhui		
Xianning CSG Energy Conservation Glass Co., LTD.	Zhu Yu		
Xinyi Glass (Jiangsu) Company Limited	Qu Jianhua	Zhang Zihao	
XYG North America Corp.	Joanne Loh	Lawrence Tao	
Yakut Cam A.S	Fatih Poyraz	Murat Tuncer	
Yantai Dongfang Glass Co., Ltd	Mr. Xing Jinwei		
Yildiz Cam San. Tic. A.S.	Onur Ercan	Cagla Bicer	
YinJian DongGuan Glass Engineering Co., Ltd.	Li Ming		
YKK AP America	Scott Blake		
Zhaoqing CSG Energy Conservation Glass Co., Ltd	Yubin Zeng	Edwin Cao	
Zhongli Glass Co., Ltd	Meng Qingxian		

February 2023
COMMUNICATIONS

In all matters concerning the administration and implementation of the IGCC® Certification Program, correspondence may be directed to any of the following:

IGCC ® Board of Governors
Dennis Johnson, President
Raths, Raths & Johnson
500 Joliet Road, Suite 200
Willowbrook, IL 60527
Telephone: (312) 325-0915
Email: dkjohnson@rrj.com

IGCC ® Certification Committee
Joe Erb, Chairman
Quanex, Inc.
800 Cochran Avenue
Cambridge, OH 43725
Telephone: (740) 439-2338
Fax: (740) 439-0120
Email: joe.erb@quanex.com

Insulating Glass Certification Council
John G. Kent, Administrative Manager
PO Box 730, 205 West Main Street
Sackets Harbor, NY 13685
Telephone: (315) 646-2234
Fax: (315) 646-2297
Email: igcc@amscert.com

Legal Counsel
Leland J. Badger
Howe & Hutton, Ltd.
1717 Pennsylvania Ave. NW, Suite 1025
Washington, DC 20006
Telephone: (202) 466-7252 (ext. 101)
Fax: (202) 466-5829
Email: ljb@howehutton.com

IGCC® PARTICIPANTS (Suppliers)

Allmetal
3361 Fulton Avenue
Muskegon, MI 49441
Telephone: (231) 755-5256
Jon DeVoogd
Email: jdevoogd@allmetal-inc.com

Chem Source
2751 East Chapman Avenue
Fullerton, CA 92831
Telephone: (714) 871-5520
Diana Dai
Email: Chems@msn.com

Delchem Inc
PO Box 10703
Wilmington, DE 19802
Telephone: (302) 426-1800
Mike Fagioli
Email: mfagioli@delchem.com

The Dow Chemical Company
2200 W. Salzburg Rd.
Midland, MI 48686
Telephone: (989) 496-5976
Steve Altum
Email: s.altum@dow.com

FDR Design Inc.
303 12th Avenue South
Buffalo, MN 55313
Telephone: (763) 682-6096
Randi Ernst
Email: rle@fdrdesign.com

Fenzi North America Inc.
11 Dansk Court
Toronto, ON M9W 5N6 Canada
Telephone: (416) 674-3831
Joe Saad
Email: j.saad@fenzi-na.com

HB Fuller/Kommerling
1200 Willow Lake Boulevard
St. Paul, MN 55110
Telephone: (651) 236-5401
Brian White
Email: brian.white@hbfuller.com

Helima-Helvetion International
795 Duncan Reidville Road
Duncan, SC 29334
Telephone: (864) 439-6600
Anthony McCall
Email: tmccall@helimasc.com

February 2023

IGCC® PARTICIPANTS (Suppliers)
(continued)

Leading Edge
1333 East Highland Road, Suite C
Macedonia, OH 44056
Telephone: (440) 786-2444
Dave Thoman
Email: dave@leadingedge95.com

Quanex, Inc.
800 Cochran Avenue
Cambridge, OH 43725
Telephone: (740) 439-2338
Joe Erb
Email: joe.erb@quanex.com

Sika Corporation
30800 Stephenson Highway
Madison Heights, MI 48071
Telephone: (440) 261-2078
Jim Blamble
Email: blamble.james@us.sika.com

Tremco
3735 Green Road
Beachwood, OH 44122
Telephone: (800) 321-7906
Rick Vallejo
Email: RVallejo@tremcoinc.com

PDS IG
1850 Prairie Street
Prairie du Sac, WI 53578
Telephone: (303) 349-0800
Michael Rapp
Email: Mike.Rapp@pdsigholding.com

Ramapo Sales & Marketing, Inc.
2440 Clements Ferry Road, Suite C
Charleston, SC 29492
Telephone: 843-747-2577
Jason Douglas
Email: jason@ramaposales.com

Technoform Glass Insulation, NA
1755 Enterprise Parkway, #300
Twinsburg, OH 44087
Telephone: (330) 487-6663
Helen Sanders
Email: helen.sanders@technoform.com

Vetrotech Saint Gobain
Sonnenwiesenstrasse 15
Kreuzlingen, 8280
Switzerland
41-71-686-9286
Peter Appel
Email: Peter.Appel@saintgobain.com

IGCC® PARTICIPANTS (Non-Suppliers)

Dr. Joseph E. Minor
Consulting Engineer
PO Box 603
Rockport, TX 78381

Robert Schwartz
Skidmore, Owings & Merrill
103 Hooverton Place
East Windsor, NJ 08520

Kenny C. White
Architectural Testing Inc. (an Intertek Company)
2524 E. Jensen Ave.
Fresno, CA 93706

February 2023

IN RECOGNITION OF PAST PRESIDENTS WHO SERVED IGCC® SINCE ITS INCEPTION

Roger D. O'Shaughnessy	Cardinal IG	1977-1979
Donald J. Vild	LOF Glass	1979-1981
Colin S. Brady	Twin Pane	1981-1982
Robert G. Spindler	PPG	1982-1983
Jerry Catalano	Hordis Brothers	1983-1985
Dr. Joseph Minor	University of Missouri	1985-1989
Mitchell D. Edwards	SPI Glass Corp.	1989-1992
John Colapietro	Tempglass, Inc.	1992-1993
Robert G. Spindler	Cardinal IG	1993-1996
James Krahn	Marvin Windows	1996-1999
Mark Cody	AFG Industries	1999-2002
Lyle N. Krohnberg	Viracon, Inc.	2002-2004
Mike Grossman	Vitro America, Inc.	2004-2007
Ray Wakefield	Trulite Industries	2007-2011
James Krahn	Marvin Windows	2011-2012
Don Boutelle	Viracon, Inc	2012-2015
Bruce Kaskel	Wiis, Janney, Elstner Associated, Inc	2015-2019

**MEETINGS OF THE
CERTIFICATION COMMITTEE**

The Certification Committee of the Insulating Glass Certification Council meets annually (Rev. 1/29/2018). Interested persons may obtain minutes of earlier meetings by visiting the web-page at www.igcc.org or by contacting the Insulating Glass Certification Council.

By-laws and a copy of the annual tax return is available by contacting the Insulating Glass Certification Council which is a 501 (C)(3) Not-for-Profit corporation.

Certification in this directory is up to date as of the date of issue; however, products may be authorized to use the permanent label or authorization removed from time to time. Please contact the IGCC® office for the latest up-to-date information.

Direct all requests and/or any comments to:

~ ADMINISTRATION ~

Administrative Management Systems, Inc. (AMS)
PO Box 730
205 West Main Street
Sackets Harbor, New York 13685
Telephone: 315-646-2234
Fax: 315-646-2297
E-mail: igcc@amscert.com
Website: www.igcc.org

~ADMINISTRATIVE STAFF~

John G. Kent, Administrative Manager
Kristin Best, Program Manager
Erin Contryman, Program Coordinator
Olivia Aubin, Program Coordinator
Alicia Deveau, Program Coordinator
Taylor Rowe, Program Coordinator

CERTIFIED PRODUCT KEY

Revision Date 2/1/2023

Sealants:

HM	=	Hot Melt Butyl
MPS	=	Modified Polysulfide
RHM	=	Reactive Hot Melt
PIB	=	Polyisobutylene
PS2	=	Two-Component Polysulfide
PU2	=	Two-Component Polyurethane
S1	=	One-Component Silicone
S2	=	Two-Component Silicone

Construction Components/

Connectors/Fabrication Techniques:

K	=	Corner Key
LC	=	Linear Connection
BC#	=	Bent Corners (1, 2, 3, or 4)
MC#	=	Mechanical Corners (1, 2, 3 or 4)
AP	=	Aperture Plug
CT	=	Capillary Tubes
PT	=	Point Support Aperture
SP	=	Seal Penetration
AF	=	Aluminum Foil
B	=	Butyl
P	=	Plastic
MT	=	Mylar Tape

Cavity Pressure Compensation (CPC):

Ref Guideline G.0

TI	=	Tubes Inserted
HR	=	Holes Resealed
PA	=	Pressure Adjusted
RS	=	Relief System
PF	=	Post Fabrication
OT	=	Other (uncategorized)

Internal Components (IC): Ref. G.8

BA	=	Bars, grills, muntins
BL	=	Blinds
GI	=	Glass, or other glazing materials
OI	=	Other

Construction Materials:

AA	=	Anodized Aluminum
MA	=	Mill Finish Aluminum
GS	=	Galvanized Steel
SS	=	Stainless Steel
CS	=	Chrome Coated Steel
ZS	=	Nickel/Zinc Plated Steel
US	=	U-Channel (Stainless Steel)
UT	=	U-Channel (Tin Plate Steel)

Desiccants:

LF	=	Loose Fill Desiccant
IB	=	Imbedded Desiccant System
DM	=	Desiccated Matrix

Integrated Spacer Systems – Generic:

BCS	=	Butyl Composite Spacer
BFS	=	Butyl Flexible Spacer
BPS	=	Butyl Polycarbonate Spacer
BSS	=	Butyl Sealant Spacer
DPHS	=	Desiccated Plastic Hybrid Stainless Steel
FSA	=	Foam Spacer Aluminum
FSCS	=	Foam Spacer Chrome Steel
FSF	=	Foam Spacer Metalized Foil
FSNF	=	Foam Spacer Non-Metal Foil
PHA	=	Plastic Hybrid Aluminum
PHCS	=	Plastic Hybrid Chrome Steel
PHF	=	Plastic Hybrid Foil
PHNF	=	Plastic Hybrid Non-Metal Foil
PHSS	=	Plastic Hybrid Stainless Steel
RTP	=	Reactive Thermoplastic Spacer
TP	=	Thermoplastic Spacer

Substrates:

U	=	Uncoated (Clear)
C3	=	Sputter Coated, Non-Edge Deleted (Soft)
C2	=	Sputter Coated, Edge Deleted (Soft)
C1	=	Pyrolytic Coated (Hard)
SCF	=	Suspended Coated Film

Gases:

AR	=	Argon
KR	=	Krypton
CO	=	Carbon Dioxide (CO ₂)
BG	=	Blend (Specifically % and Composition)

Gas Content: Ref. Guideline 11.0

Yes	=	GCIA measured valued for initial content, 90% or greater; after weather 80% or greater. Testing for Argon value only at this time. (See guideline A.GC.1)
-----	---	---

Other:

VG	=	Vacuum Insulating Glass Unit
IN	=	Inactive certification (See guideline G.38)
PC	=	Provisional Certification (See guidance note #2 & 13.0)

Note: The materials of construction as listed above are presented as general information only. The designations for the various component parts are generic and do not reflect specific product modifications or technical differences within a component. For more detailed information on components, contact your insulating glass supplier.

UNDER EACH COMPANY'S NAME IS THEIR IGCC®/IGMA® PERMANENT LABEL

IGCC®/IGMA® CERTIFIED PRODUCTS

<u>LICENSEE</u>	<u>CERTIFICATION NUMBER</u>	<u>FRAME CONSTRUCTION</u>	<u>SUBSTRATE</u>	<u>SPACER</u>	<u>DESICCANT</u>	<u>SEALANT</u>	<u>INTERNAL COMPONENTS</u>	<u>GCIA</u>
A.N. ALODAN & SONS CO. GLASS & ALUMINIUM FACTORY P.O. Box 797 Riyadh 1st Industrial Area Riyadh 11421 Saudi Arabia +966 11 448 3444 Komate IGCC®/IGMA® 2022	4929	BC4/ALLC	U/C3/U	MA/MA	LF/LF	PIB/S2		
Advanced Impact Technologies 2310 Starkey Road Largo, FL 33771 USA 727-287-4620 AIT IGCC(R)/IGMA(R) 22	5079	BC4/GSLC	U/C2	AA	LF	PIB/S2		
Advantage Glass Corp 601 West Carboy Road Mount Prospect, IL 60056 USA 847-290-1707 Advantage Glass IGCC(R)/IGMA(R) 2022	5743	BC4/PLC	U/C2	ZS	LF	PIB/S2		Yes
AGC Flat Glass (Thailand) PLC. 200 Moo 1, Suksawad Road Pak Khlong Bang Pla Kod Phra Samut Chedi, Samut Prakan 10290 Thailand 66-2815-5000x1982	4432	MC4/ALK	U/C3/U	MA/MA	LF/LF	PIB/S2		Yes
AGNORA LTD 200 Mountain Road Collingwood, ON L9Y4V5 Canada 7054446654	4766 5619	BC4/SSLC BC4/SSLC	U/C1 U/C2/U	PHSS SS/SS	LF LF/LF	PIB/S2 PIB/S2		Yes
Al Abbar Architectural Glass Sanaa St., PO Box 1626 Ras Alkhor, Industrial Estate Dubai United Arab Emirates 104-333-1362	2977	BC4/ALLC	U/C2	MA	LF	PIB/S2		
Al Andalus Glass Factory Co. 7602 196 Street 2nd Industrial City Riyadh, Riyadh 14333 Saudi Arabia + 966 6 577 17215	5403 5404	BC4/ALLC BC4/ALLC	U/U U/U	AA AA	LF LF	PIB/S2 PIB/S2		
Aldora Aluminum and Glass Products Inc. 7421 E. Spartan Blvd. Charleston, SC 29418-8462 USA 843-552-6377 Aldora(SC) IGCC(R)/IGMA(R) 4QT 22	2853	BC3/MC1/MT	U/C2	FSF	IB	HM	BA	

<u>LICENSEE</u>	<u>CERTIFICATION NUMBER</u>	<u>FRAME CONSTRUCTION</u>	<u>SUBSTRATE</u>	<u>SPACER</u>	<u>DESICCANT</u>	<u>SEALANT</u>	<u>INTERNAL COMPONENTS</u>	<u>GCIA</u>
Aldora Aluminum and Glass Products, Inc. 280 Enterprise Dr. Newport News, VA 23603 USA 330-990-2541	5849	BC4/GSLC	U/C2	AA	LF	PIB/S2		
Aldora Aluminum and Glass Products, Inc. 1903 Cypress Lake Dr Orlando, FL 32837-8459 USA 407-960-3933 Aldora Orlando IGCC(R)/IGMA(R) #5497 2022	5497	MC4/PK	U/C2	AA	LF	PIB/S2	BA	
All Counties Glass 2020 A East Miner Avenue Stockton, CA 95205 USA 209-888-8720	5108	MC4/PK	U/C2	AA	LF	RHM/RHM	BA	
All Weather Windows 18550, 118A Avenue North West Edmonton, AB T5S 2K7 Canada 780-451-0670 AWW-1 IGCC®/IGMA® mm/dd/yy Cert #	2539 3938	BC3/MC1/MT BC3/MC1/SS	U/C2/U U/C2/U	FSF/FSF US/US	IB/IB DM/DM	RHM RHM	BA BA	Yes Yes
All Weather Windows Glass Ltd. 14415 - 128 Avenue Edmonton, AB T5L 3H3 Canada 780-482-8732	4815 4846 IN 5094 5749 PC 5750 PC	BC3/MC1/MT BC3/MC1/MT BC3/MC1/MT BC4 BC4	U/C2/U U/C2/U U/C2/U U U	FSF/FSF FSF/FSF FSF/FSF RTP/RTP RTP/RTP	IB/IB IB/IB IB/IB IB/IB IB/IB	PIB/S2 PS2 PS2 RTP/S2 RTP/PS2	BA BA BA BA BA	Yes Yes Yes Yes Yes
Aluminum Technology Auxiliary Industries PO Box 40625 St #31 Salwa Industrial Area Doha 40625 Qatar 97444602334 ALUTEC IGCC/IGMA 2022	3267	BC4/GSLC	U/U	MA	LF	PIB/S2		
American Glass American Glass 2801 N. LeCompte Rd. Springfield, MO 65803 USA 417-866-8361 American Glass IGCC(R) IGMA (R) '22	5375	MC4/PK	U/C2	AA	LF	PIB/S2	BA	Yes
American Insulated Glass 102 East Fields Street PO Box 475 Dallas, NC 28034 USA 704-917-0880 AIG IGCC(R)/IGMA(R) 2022	3158 3518 5293	MC4/PK BC4/GSLC BC4/GSLC	U/C2 U/C2 U/C2	AA AA AA	LF LF LF	PIB/RHM PIB/S2 PIB/RHM	BA BA BA	Yes Yes

<u>LICENSEE</u>	<u>CERTIFICATION NUMBER</u>	<u>FRAME CONSTRUCTION</u>	<u>SUBSTRATE</u>	<u>SPACER</u>	<u>DESICCANT</u>	<u>SEALANT</u>	<u>INTERNAL COMPONENTS</u>	<u>GCIA</u>
American Insulated Glass Inc. 2700 19th St. North Birmingham, AL 35207 USA 336-341-1565	5083 5084	MC4/PK BC3/MC1	U/C2 U/C2	AA FSF	LF IB	PIB/S2 HM	BA BA	
American Insulated Glass LLC. 2190 Urbana Pike. Ijamsville, MD 21754 USA 301-831-1960	5417 5565	BC4/GSLC BC4/GSLC	U/C2 U/C2	AA AA	LF LF	PIB/PU2 PIB/S2		
American Insulated Glass LLC. 12707 Eckles Road Plymouth Township, MI 48170 USA 734-656-3900 GLGD IGCC(R)/IGMA(R) 2022	3572 4420 5521 5522	MC4/PK MC4/PK MC4/PK MC4/PK	U/C1 U/C1 U/C1 U/C1	AA AA PHSS PHSS	LF LF LF LF	PIB/PS2 PIB/S1 PIB/PS2 PIB/S2	BA BA BA BA	
American Insulated Glass, LLC 3965 East Conley Road PO Box 750 Conley, GA 30288 USA 404-361-9154	4967 5070	MC4/PK BC3/MC1	U/C2 U/C2	AA FSF	LF IB	PIB/S2 RHM	BA BA	
Andersen Corporation 71 Second St Strathroy, ON N7G 3H8 Canada 651-264-5150 Andersen IGCC(R)/IGMA(R) Date	2373 5039	BC3/MC1/MT BC3/MC1/MT	U/C2/U U/C2	FSF/FSF FSF	IB/IB IB	RHM RHM	BA BA	Yes Yes
AntCam Cam Pazarlama San. Ve Tic. A.S. Organize Sanayi Bolgesi 2.Kisim 21.Cad. No.18 Antalya, Dosemealti 07190 Turkey 00902423402037 ANTCAM IGCC(R)/IGMA(R) Date	5351 5352	MC4/PK MC4/PK	U/C2 U/C2	PHSS PHSS	LF IB	PIB/S2 PIB/S2		Yes
Architectural Glass Products, LLC. 6200 Maple Avenue St. Louis, MO 63130 USA 314-725-8088 Architectural Glass Products LLC IGCC@IGMA@ 22	2664 2666	MC4/PK MC4/PK	U/C2 U/C2	AA PHSS	LF LF	PIB/PU2 PIB/PU2		
Arino Duglass Poligono Industrial Royales Bajos S/N La Puebla De Alfinden Zaragoza 50171 Spain +34 976108008 Arino Duglass - Cert# - IGCC IGMA - Date	5216 5217	BC4/SSLC BC4/SSLC	U/C2 U/C2	PHSS MA	LF LF	PIB/S2 PIB/S2		Yes Yes

<u>LICENSEE</u>	<u>CERTIFICATION NUMBER</u>	<u>FRAME CONSTRUCTION</u>	<u>SUBSTRATE</u>	<u>SPACER</u>	<u>DESICCANT</u>	<u>SEALANT</u>	<u>INTERNAL COMPONENTS</u>	<u>GCIA</u>
AROW Global Corporate 924 North Park View Circle Mosinee, WI 54455 USA 715-318-7299	5677	BC4/MT	U	FSF	IB	RHM		
Associated Materials, Inc. - Central 3773 State Road Cuyahoga Falls, OH 44223 USA 330-922-2069 AWCC IGCC®/IGMA® + date	3017 3332 3503 3951 4433	BC4/ZS BC4/ZS BC4/ZS BC4/ZS BC3/MC1/MT	U/C3/U U/C3/U U/C3/U U/C3/U U/C3/U	UT/UT US/US US/US UT/UT FSF/FSF	DM/DM DM/DM DM/DM DM/DM IB/IB	HM HM HM HM HM	BA BA BA BA BA	Yes Yes Yes Yes Yes
Associated Materials, Inc. - Midwest 3820 44th Ave. SW Cedar Rapids, IA 52401 USA 330-922-2069 AWCMW IGCC®/IGMA® + date + Line#	3171 3481 3717 4407 4408 5791	BC3/MC1/MT BC4/ZS BC4/ZS BC4/ZS BC4/ZS BC4/ZS	U/C3/U U/C3/U U/C3/U U/C3/U U/C3/U U/C3	FSF/FSF UT/UT US/US US/US UT/UT US/US	IB/IB DM/DM DM/DM DM/DM DM/DM IB/IB	HM HM HM HM HM HM	BA BA BA BA BA BA	Yes Yes Yes Yes Yes Yes
Associated Materials, Inc. - Northwest 2801 78th Avenue East Fife, WA 98424 USA (425) 481-7101 AWCNW IGCC(R)/IGMA(R) + date	3034 4091 4252 5413 5414	BC3/MC1/MT/TI BC4/ZS BC4/ZS BC4/ZS BC4/ZS	U/C3/U U/C2/U U/C3/U U/C3/U U/C3/U	FSF/FSF US/US UT/UT UT/UT US/US	IB/IB DM/DM DM/DM DM/DM DM/DM	HM RHM/HM RHM/HM RHM/HM RHM/HM	BA BA BA BA BA	Yes Yes Yes Yes Yes
Associated Materials, Inc. - Southeast 3800 Farmgate Road Kinston, NC 28501 USA 252-527-5050 AWCSE IGCC(R)/IGMA(R) + date	3103 3199 3702 3904 3905	BC3/MC1/MT BC4/ZS BC4/ZS BC4/ZS BC4/ZS	U/C3/U U/C3/U U/C3/U U/C3/U U/C3/U	FSF/FSF UT/UT US/US UT/UT US/US	IB/IB DM/DM DM/DM DM/DM DM/DM	HM HM HM HM HM	BA BA BA BA BA	Yes Yes Yes Yes Yes
Associated Materials, Inc. - Southwest 7550 E. 30th St. Yuma, AZ 85365 USA 928-344-6500 AWCSW IGCC(R)/IGMA(R) + date	2551 4108 4309 4609 5530	BC3/MC1/MT/TI BC4/ZS BC4/ZS BC4/ZS BC4/ZS	U/C3/U U/C2/U U/C3/U U/C2/U U/C3	FSF/FSF US/US US/US UT/UT UT/UT	IB/IB DM/DM DM/DM DM/DM DM/DM	HM HM HM HM HM	BA BA BA BA BA	Yes Yes Yes Yes Yes
Astiglass S.L. POLIGONO LA CAMPIÑA FASE 4 CALLE LA DEHESA DE LAS YEGUAS N°1 Ecija, Sevilla 41400 Spain +34 954 832 665 ASTIGLASS +IGCC(R)/IGMA(R) + Date	5262 5263	BC4/PLC MC4/PK	U/C2 U/C2	AA PHSS	LF LF	PIB/S2 PIB/S2		Yes Yes
Aurora Windows and Doors 44980 S. Grimmer Blvd Fremont, CA 94538 USA 650-780-9163	5541	BC3/MC1/MT	U/C2	FSF	IB	HM	BA	

<u>LICENSEE</u>	<u>CERTIFICATION NUMBER</u>	<u>FRAME CONSTRUCTION</u>	<u>SUBSTRATE</u>	<u>SPACER</u>	<u>DESICCANT</u>	<u>SEALANT</u>	<u>INTERNAL COMPONENTS</u>	<u>GCIA</u>
Beijing Haiyangshunda Northtech Glass Ltd. No. 1 North Road Daxing District, Beijing 100000 China +861082032601	4646	BC4/GSLC	U/U	MA	LF	PIB/S2		
Beijing Wuhua Tianbao Glass Co. NO. 1 Renli Road Liqiao Town Shunyi District, Beijing 101304 China +86-10-69485045	4243 5353	BC4/GSLC BC4/GSLC	U/C2 U/C2	AA PHSS	LF LF	PIB/S2 PIB/S2		Yes Yes
Blue Star Glass Inc. 2300 US Highway 1 Building 31 North Brunswick, NJ 08902 USA 732-422-1272	4618 4619 5543	BC4/GSLC BC4/GSLC BC4/GSLC	U/C2 U/C2 U	AA MA PHSS	LF LF LF	PIB/S2 PIB/S2 PIB/S2	BA BA BA	Yes Yes Yes
Builders First Source 850 White Circle Court PO Box 4237 Marietta, GA 30060 USA 678-819-6163 BMC IGCC(R) IGMA(R) + weekYear	3693	BC3/MC1	U/C2	BPS	IB	BPS	BA	
BVGLAZING SYSTEMS 131 Caldari Road Concord, ON L4K 3Z9 Canada 905-738-8600 BV Glazing Systems IGCC(R)/IGMA(R) Concord 2021	5105 5106	BC4/GSLC BC4/GSLC	U/C2/U U/C2/U	SS/SS PHSS/PHSS	LF/LF LF/LF	PIB/S2 PIB/S2		Yes Yes
Camyapi Cam Paz. Ins. Taah. Tic.ve San. Ltd. Sti Makine Ihtisas Organize Sanayi Bolgesi Demirciler Mahallesi 5 Cadde No: 6 Kocaeli, Dilovasi 41455 Turkey +90 262-444-12-26 Cam Yapi IGCC (R)/IGMA(R) + Date	5260	BC4/PLC	U/C2	MA	LF	PIB/S2		
Cardinal CT 140 Carey Drive Utica, OH 43080 USA 740-892-2324	4897	BC3/MC1/MT	U/U	FSF	IB	HM		
Cardinal IG 6415 South Apache Rd. Buckeye, AZ 85326 USA 480-486-4105 CIG 13 IGCC(R)/IGMA(R) + date	4684 IN 4725 IN 5618 5788 5789	BC4/PLC/TI BC4/PLC BC4/ALLC BC4/PLC/TI BC4/PLC/TI	U/C2 U/C2/U U/C2 U/C2 U/C2	SS SS/SS AA SS/SS SS	LF LF LF LF/LF LF	PIB/S2 PIB/S2 PIB/S1 PIB/S1 PIB/S1	BA BA BA	Yes Yes Yes Yes Yes

<u>LICENSEE</u>	<u>CERTIFICATION NUMBER</u>	<u>FRAME CONSTRUCTION</u>	<u>SUBSTRATE</u>	<u>SPACER</u>	<u>DESICCANT</u>	<u>SEALANT</u>	<u>INTERNAL COMPONENTS</u>	<u>GCIA</u>
Cardinal IG 4611 15th Ave N.W. Fargo, ND 58102 USA	1464 1492 3456	BC4/PLC/TI/MT BC4/ALLC/AF/TI BC4/PLC/MT/TI	U/C2 U/C2 U/C2/U	SS AA SS/SS	LF LF LF/LF	PIB/S1 PIB/S1 PIB/S1	BA BA BA	Yes Yes Yes
701-492-0920 Cardinal IGCC(R)/IGMA(R) CIG-6 Date LoE2	3457 4878 IN	BC4/ALLC/AF/TI BC4/PLC/CT/MT	U/C2/U U/C2/U	AA/AA SS/SS	LF/LF LF/LF	PIB/S1 PIB/S1	BA BA	Yes Yes
Cardinal IG 301 E. McSwain Drive PO Box 99 Fremont, IN 46737 USA	1453 3447 5544	BC4/SSLC/AF/TI BC4/PLC/TI BC4/PLC/AF/TI	U/C2 U/C2/U U/C1/C2	SS SS/SS AA	LF LF/LF LF	PIB/S1 PIB/S1 PIB/S1	BA BA BA	Yes Yes Yes
260-495-4105 CIG-5 IGCC(R)/IGMA(R) + Date								
Cardinal IG 716 North East 6th Street PO Box 99 Greenfield, IA 50894 USA	1030 3539	BC4/PLC/TI BC4/PLC/TI	U/C2/U U/C2	SS/SS SS	LF/LF LF	PIB/S1 PIB/S1	BA BA	Yes/CPC Yes
641-343-7113 Cardinal IG IGCC® IGMA® CIG-2 "date"								
Cardinal IG 3125 Neal Creek Mill Road Hood River, OR 97031 USA	1923 1924 2553	BC4/ALLC/TI BC4/PLC/TI BC4/PLC/TI	U/C2 U/C2 U/C2/U	AA SS AA/AA	LF LF LF/LF	PIB/S1 PIB/S1 PIB/S1	BA BA BA	Yes Yes Yes
541-354-1280 Cardinal IG CIG 9 IGCC(R)/IGMA(R) + date	2554 4683	BC4/PLC/TI BC4/PLC	U/C2/U U/C2	SS/SS SS	LF/LF LF	PIB/S1 PIB/S2	BA BA	Yes Yes
Cardinal IG 50 Elmwood Road Crestwood Industrial Park Mountain Top, PA 18707 USA	2221 2222 4721	BC4/ALLC/TI BC4/PLC/TI BC4/PLC/TI	U/C2/U U/C2 U/C2/U	AA/AA SS SS/SS	LF/LF LF LF/LF	PIB/S1 PIB/S1 PIB/S1	BA BA BA	Yes Yes Yes
570-474-3100 CIG 11 IGCC(R)/IGMA(R) Date code								
Cardinal IG 4185 SW 13th St. Ocala, FL 34474 USA	3661 4960	BC4/PLC BC4/PLC	U/C2 U/C2/U	SS SS/SS	LF LF/LF	PIB/S1 PIB/S1	BA	Yes Yes
352-291-6879 Cardinal IG IGCC(R)/IGMA(R) CIG-12 2023								
Cardinal IG 1011 E. Madison St. Spring Green, WI 53588 USA	1036 1306 3168	BC4/PLC/TI BC4/ALLC/TI BC4/ALLC/TI	U/C2 U/C2 U/C2/U	SS AA AA/AA	LF LF LF/LF	PIB/S1 PIB/S1 PIB/S1	BA BA BA	Yes Yes Yes
(608) 588-3846 Cardinal IG IGCC(R)/IGMA(R) CIG-3 Quarter/year/coating	3169	BC4/PLC/TI	U/C2/U	SS/SS	LF/LF	PIB/S1	BA	Yes

<u>LICENSEE</u>	<u>CERTIFICATION NUMBER</u>	<u>FRAME CONSTRUCTION</u>	<u>SUBSTRATE</u>	<u>SPACER</u>	<u>DESICCANT</u>	<u>SEALANT</u>	<u>INTERNAL COMPONENTS</u>	<u>GCIA</u>
Cardinal IG 1620 Town Line Road Tomah, WI 54660 USA 608-372-3300 IGCC(R)/IGMA(R) CIG-4 current date	1039 1295 5728	BC4/PLC/TI BC4/ALLC/TI BC4/PLC/TI	U/C2/U U/C2 U/C2	SS/SS AA SS	LF/LF LF LF	PIB/S1 PIB/S1 PIB/S2	BA BA BA	Yes Yes Yes
Cardinal IG 2132 Cardinal Park Drive Vinton, VA 21179 USA 540-892-5600 CIG 10 IGCC(R)/IGMA(R) + date	1970 1971 3768	BC4/PLC/TI BC4/ALLC/TI BC4/PLC/TI	U/C2 U/C2 U/C2/U	SS AA SS/SS	LF LF LF/LF	PIB/S1 PIB/S1 PIB/S1	BA BA BA	Yes Yes Yes
Cardinal IG 201 Cardinal Road Waxahachie, TX 75165 USA 972-937-4969 "Customer" IGCC(R)/IGMA(R) CIG-8 Date	1574 1718 2838	BC4/ALLC BC4/PLC/TI BC4/PLC/TI	U/C2 U/C2 U/C2/U	AA SS SS/SS	LF LF LF/LF	PIB/S1 PIB/S1 PIB/S1	BA BA BA	Yes Yes Yes
Carey Glass UC Limerick Road Nenagh, Co. Tipperary E45 XV81 Ireland 353-87-204-2779	5047 5048	BC4/PLC BC4/PLC	U/C2 U/C2	PHSS AA	LF LF	PIB/S2 PIB/S2		Yes Yes
Cascade Windows Inc. 3950 Medford Dr. Loveland, CO 80538 USA 509-847-1331 IGCC(R)/IGMA(R) WPI 5 2023	5302 5839	BC3/MC1/MT BC3/MC1	U/C2 U/C2	FSF FSF	IB IB	HM HM	BA BA	
Cascade Windows Inc. 2225 S 75th Avenue #140 Phoenix, AZ 85043 USA 480-736-8988 WPI20 IGCC(R)/IGMA(R) + date	4800 5790	BC3/MC1/ZS BC3/MC1	U/C2 U/C2	UT FSF	DM IB	HM HM	BA BA	Yes
Cascade Windows Inc. 5323 Harold Gatty Drive Salt Lake City, UT 84116 USA 801-359-2950 IGCC(R)/IGMA(R) WPI4 + date	4318 5007 5844	BC3/MC1/ZS/TI BC3/MC1 BC3/MC1	U/C2 U/C2 U/C2	UT FSF FSF	DM IB IB	HM HM HM	BA BA BA	Yes Yes
Cascade Windows Inc. 10507 E. Montgomery Drive Spokane, WA 99206 USA 509-789-3049 IGCC(R)/IGMA(R) WPI1 + date	3495 3792 5606 5707	BC3/MC1/ZS/TI BC3/MC1 BC3/MC1 BC3/MC1/ZS	U/C2 U/C2 U/C2 U/C2	UT FSF FSF UT	DM IB IB DM	HM HM HM HM	BA BA BA BA	 Yes Yes

<u>LICENSEE</u>	<u>CERTIFICATION NUMBER</u>	<u>FRAME CONSTRUCTION</u>	<u>SUBSTRATE</u>	<u>SPACER</u>	<u>DESICCANT</u>	<u>SEALANT</u>	<u>INTERNAL COMPONENTS</u>	<u>GCIA</u>
Cascade Windows Inc. 10255 SW Spokane Court Tualatin, OR 97062-8823 USA 503-692-6167 IGCC(R)/IGMA(R) WPI3 + date	5605 5609	BC3/MC1/ZS BC3/MC1	U/C2 U/C2	UT FSF	DM IB	HM HM	BA BA	Yes Yes
Central Valley Glass & Screen, Inc. 5854 88th St. Sacramento, CA 95828-1104 USA 916-421-5293	5104 5466	BC3/MC1/MT BC4/GSLC	U/C2/U U/C2	FSF/FSF AA	IB/IB LF	HM PIB/PS2	BA BA	 Yes
Changshu High-Tech Energy-Saving Dorwin Co., Ltd. Industrial Park, Yanxiang Village Shanghu Town Changsu, Jiangsu 215551 China 86-0512-52122530 CSOTK 09/22 IGCC®/IGMA® 4894	4894 5125	MC4/PK MC4/PK	U/C2 U/C2	PHA AA	LF LF	PIB/PS2 PIB/PS2	BL BL	
ChangShu MayBo Glass Co., Ltd Zhouhang, Haiyu Town Changshu, Jiangsu 215517 China 0512-52590663	4225 4227 5098	BC3/MC1/MT MC4/PK BC3/MC1	U/C3 U/C3 U/C3	FSF AA BCS	IB LF IB	PU2 PIB/PU2 BCS/PS2	GI GI GI	Yes Yes Yes
Changshu Sedy Glass Specialties Co., Ltd Shengfa Village, Meili Town Changshu, Jiangsu 215511 China 0512-52215318	5433	BC3/MC1	U/U	BCS	IB	BCS/PS2	GI	
Changshu Sysen Glass Products Co., Ltd. Zhoushi Road Shiqiao Village Meili Town Changshu Suzhou City, Jiangsu Province 215511 China 0512-52333829	4459 4460	MC4/PK BC3/MC1	U/C3 U/C3	AA BCS	LF IB	PIB/PS2 BCS/PS2	GI GI	Yes Yes
Changshu Weier Glass Products Co. Ltd. Haiyu Town Changshu, Jiangsu 215519 China 86-512-52569644	3073 4953 5367 5713	MC4/PK BC3/MC1 MC4/PK BC3/MC1	U/C3 U/U U/U U/U	AA BCS MA BCS	LF IB LF IB	PIB/PU2 BCS/PS2 PIB/PS2 BCS/PS2	GI GI BL GI	Yes
Changshu Zhongqin Building Material Co., Ltd No. 18 Xuanli Road Meili Town, Changshu Suzhou, Jiangsu 215500 China +86-512-52389805	5579	MC4/PK	U/C1	AA	LF	PIB/PS2	BL	

<u>LICENSEE</u>	<u>CERTIFICATION NUMBER</u>	<u>FRAME CONSTRUCTION</u>	<u>SUBSTRATE</u>	<u>SPACER</u>	<u>DESICCANT</u>	<u>SEALANT</u>	<u>INTERNAL COMPONENTS</u>	<u>GCIA</u>
Changshu ZhongXin Building Materials Co., Ltd. Meili Town Changshu, Jiangsu 215500 China	3435 4012 4122 4124	MC4/PK MC4/PK BC3/MC1 BC3/MC1	U/C2 U/C2 U/C2 U/C2	AA AA BCS BCS	LF LF IB IB	PIB/PS2 PIB/PS2 BCS BCS/PS2	GI GI GI GI	
Changxing Kibing Energy Saving Glass Co., Ltd. Shiquan Village, Lijiaxiang Town, Changxing County Huzhou City, Zhejiang 313100 China +86-575-88730760	4732	BC4/GSLC	U/C2	AA	LF	PIB/S2		
Chin Ta Glass Co., Ltd. No 39-16 Chenggong Road Dounan Township Yunlin, Taiwan 630 China 886-5-5962492	4716	BC4/GSLC	U/C2	MA	LF	PIB/S2		
Ching Chyau Co., Ltd. No. 560, Feng-lin Second Road, Da-liao District Kaohsiung City, Taiwan 831 China 886-7-7878959	2891	MC4/PK	U/C2	AA	LF	PIB/S2		
Chongqing SYP Engineering Glass Co., Ltd. No. 1 Yaopi Road, Wandong Town, Economic and Technological Development Zone Qijiang District, Chongqing 400800 China	4724	BC4/GSLC	U/C2	AA	LF	PIB/S2		Yes
Ciraylar Cam Insaat Malzemeleri San. VE TIC. A.S. Fevzi Cakmak MH. Sila Cd. No:4 Karatay, Konya 42050 Turkey 905351083135 Ciraylar Cam (*) IGCC(R)/IGMA(R) 22	5409 5447	MC4/PK MC4/PK	U U/C2	PHSS PHSS	LF LF	PIB/S2 PIB/S2		Yes
Cmech Ltd. 2 FengGuang Road ZhongXin Town ZengCheng City, Guangdong 511365 China 86-020-61737991 CMECH IGCC®/IGMA® 2022	3260 5276	MC4/PK MC4/PK	U/U U/C1	AA AA	LF LF	PIB/PS2 PIB/PS2	BL BL	
Comercial Dialum SA Panamericana Norte 18.600, Lampa Santiago 9390306 Chile 56-2-24988600 DIALUM IGCC®/IGMA® (year)	4694	BC4/GSLC	U/C2	MA	LF	PIB/S2		

<u>LICENSEE</u>	<u>CERTIFICATION NUMBER</u>	<u>FRAME CONSTRUCTION</u>	<u>SUBSTRATE</u>	<u>SPACER</u>	<u>DESICCANT</u>	<u>SEALANT</u>	<u>INTERNAL COMPONENTS</u>	<u>GCIA</u>
Complete Line Glass Wholesalers, Inc. 8175 Bracken Creek Dr San Antonio, TX 78266 USA 210-651-9873 CLGW IGCC(R)/IGMA(R) 2022	4811	BC4/GSLC	U/C2	AA	LF	PIB/S2	BA	
Consolidated Glass and Mirror, LLC 110 Jack Guynn Drive Galax, VA 24333 USA 276-236-5196 GRD-024 IGCC(R)/IGMA(R) 2022	3214 3215 3499 5148 5315 5720	BC3/MC1 BC3/MC1 BC3/MC1 BC3/MC1/MT BC3/MC1 BC3/MC1	U/C2/U U/C2 U/C2 U/C2/U U/C2/U U/C2	FSF/FSF BCS BPS FSF/FSF BPS/BPS BPS/BPS	IB/IB IB IB IB/IB IB/IB IB/IB	HM BCS BPS HM BPS BPS	BA BA BA BA BA	Yes Yes Yes Yes Yes Yes
CS ECO Glass (M) Sdn Bhd LOT 635 & 660 Kawasan Perindustrian Tuanku Jaafar Sungai Gadut, Negeri Sembilan 71450 Malaysia	4781 5410	BC4/GSLC BC4/GSLC	U/C2 U/C2	AA PHSS	LF LF	PIB/S2 PIB/S2		Yes Yes
Custom Glass Prod. Of Carolina PO Box 2049 1475 Harrison Rd. Salisbury, NC 28144 USA 704-633-4946 CGPC IGCC(R)/IGMA(R) '22	3876	MC4/PK	U/U	AA	LF	PIB/RHM	BA	
Custom Glass Products Inc. 7515 Venture Circle Weston, WI 54476 USA 715-359-2252 "Custom Glass WI IGCC(R)/IGMA(R)2022"	2979	MC4/PK	U/U	MA	LF	PIB/S2		
Diamond Glass Unit S3B Le Brocquy Ave. Park West Ind. Estate Dublin D12KT91 Ireland +353 1620 5000	5622	MC4/PK	U/C2	PHF/PHF	LF/LF	PIB/S2		Yes
Dongguan CSG Architectural Glass Co., Ltd. CSG Green Energy Industrial Park Machong Town Dongguan, Guangdong Province China 86-769-88288292	2660 4601 4602	BC4/GSLC BC4/GSLC BC4/GSLC	U/C2 U/C2 U/C2	AA PHSS SS	LF LF LF	PIB/S2 PIB/S2 PIB/S2		Yes
DongGuan Longlass Fire Resistant Technology Co., Ltd. Taokeng Wulian Industrial Park, Wulian Village Fenggang Town Dongguan, GuangDong 532695 China 86-0769-87298666	4333	BC4/GSLC	U/C2	MA	LF	PIB/S2		

<u>LICENSEE</u>	<u>CERTIFICATION NUMBER</u>	<u>FRAME CONSTRUCTION</u>	<u>SUBSTRATE</u>	<u>SPACER</u>	<u>DESICCANT</u>	<u>SEALANT</u>	<u>INTERNAL COMPONENTS</u>	<u>GCIA</u>
Donguan Ngai Wah Bending Tempering Glass Company Limited Hekeng Industrial Area, Qiaotou Town Donguan City, Guangdong Province 52300 China +86 769 81029188	4447	MC4/PK	U/C2	AA	LF	PIB/S2		
ECO Glass Production 9101 NW 87th Ave Medley, FL 33178 USA 7862533327	5460	BC3/MC1/MT	C2	FSF	IB	PIB/S2		Yes
EFCO Corporation 1000 County Road Monett, MO 65708-9214 USA 417-235-6011	2244 3459 4473 4865	BC3/MC1/AP BC4/GSLC BC4/GSLC BC4/GSLC	U/C2 U/C2 U/C2 U/C2	UT PHSS AA AA	DM LF LF LF	RHM/HM PIB/S2 PIB/S2 PIB/S2	BA	Yes Yes Yes Yes
EFCO Corp. IGCC®/IGMA® "time" "date"	4866 4901	BC4/GSLC BC3/MC1	U/C2 U/C2	PHSS UT	LF DM	PIB/S2 RHM/HM	BA	Yes Yes
Elivate Mexico Supply S. de R.L. de C.V. 4045 Spencer Street Suite B24 Las Vegas, NV 89119	5592 5593 5610 5655	BC4/SSLC BC4/SSLC BC4/SSLC BC4/GSLC	U/C2 U/C2 U/C2 U/C2	MA PHSS SS PHSS/PHSS	LF LF LF LF/LF	PIB/S2 PIB/S2 PIB/S2 PIB/S2		Yes Yes Yes Yes
Emirates Glass L.L.C. PO Box 29769 Interchange 4, Al Quoz Industrial Area Dubai United Arab Emirates 00971-47094789 Emirates IGCC®/IGMA® 2334/5547- 2022	2334 5547	BC4/ALLC BC4/ALLC	U/C2 U/C2	MA MA	LF LF	PIB/S2 PIB/S2		
Engineered Glass Products, L.L.C. 2857 S. Halsted Street Chicago, IL 60608-5907 USA 3123264710 EGP 3526 IGCC(R)/IGMA(R) 2022	3526	BC3/MC1	U/C1	BCS	IB	BCS		
Erdem Dis Ticaret A.S. Velibaba Mah. Aydos Cad. No:10 Pendik, Istanbul 34896 Turkey +902165856561 ERDEM + IGCC(R)/IGMA(R) 22	5138 5246	BC4/SSLC BC4/SSLC	U/C2/U U/C2	PHSS/PHSS AA/AA	LF/LF LF/LF	PIB/S2 PIB/S2		
Fairis C.A. 298 Verde Loma y Quis Picacha Ambato, Tungurahua 18010112 Ecuador 59332520901 FAIRIS@Insulating Glass IGCC®/IGMA® ASTME2190(#) (year)	4758 4759 5172	BC4/SSLC BC4/sSLC BC4/SSLC	U/U U/U U/C2	AA AA AA	LF LF LF	PIB/PS2 PIB/PS2 PIB/S2		Yes Yes

<u>LICENSEE</u>	<u>CERTIFICATION NUMBER</u>	<u>FRAME CONSTRUCTION</u>	<u>SUBSTRATE</u>	<u>SPACER</u>	<u>DESICCANT</u>	<u>SEALANT</u>	<u>INTERNAL COMPONENTS</u>	<u>GCIA</u>
FAKRO GP Sp. Z.0.0. ul. Wegierska 144A 33-300 Nowy Sacz VAT number: PL 734-30-11-797 Poland 481-844-4053 FGP FAKRO IGCC(R)/IGMA(R) + date	4323 4914	BC4/GSLC BC4/GSLC	U/C2 U/C2	PHSS PHSS	LF LF	PIB/PU2 PIB/S2		Yes Yes
Fenplast, Inc. 160, boul. de L'industrie Candiac, QC J5R 1J3 Canada 514-990-0012 Fenplast - Candiac, QC MM/YYYY IGCC@/IGMA@	3451	BC3/MC1/MT	U/C1/U	FSF/FSF	IB/IB	HM	BA	Yes
FG Glass Industries Pvt Ltd. 1204 Tower A, Naman Midtown Elphinstone Road Mumbai, Maharastra 400013 India +91-22-40657777	5277	BC4/GSLC	U/C2	MA	LF	PIB/S2		
Flat Glass Distributors 5355 Shawland Road Jacksonville, FL 32254 USA 904-354-5413 FGD IGCC(R)/IGMA(R) 2023	2467 IN 5221	BC3/MC1/MT BC3/MC1/MT	U/C2 U/C2	FSF FSF	IB IB	HM RHM	BA	
Flat Glass Group Co., Ltd. 1999 Yunhe Rod., Xiuzhou Industrial Zone Jiaxing, Zhejiang 314001 China 86-139-05735930	4144	BC4/GSLC	U/C2	AA	LF	PIB/S2		
Foshan Super Glass Ind. Co; Ltd. Boai Dong Road Shishan Science & Technology Zone B Nanhai District Foshan, Guangdong 528225 China +86 13101320231	5371 5372	BC4/GSLC BC4/GSLC	U/C2 U/C2/U	PHSS PHSS/PHSS	LF LF/LF	PIB/S2 PIB/S2		
Future Architectural Glass LLC P 278, Al Ghail Industrial Area PO Box 86001 Al Ghail Ras Al Khaimah United Arab Emirates 072589274	3641	BC4/SSLC	U/U	MA	LF	PIB/S2		
General Glass 6601 NE 112th Court Vancouver, WA 98662 USA 503-253-1147	3617 4231	BC4/GSLC BC4/GSLC	U/C2 U/C2	MA MA	LF LF	PIB/PS2 PIB/S2	BA BA	

<u>LICENSEE</u>	<u>CERTIFICATION NUMBER</u>	<u>FRAME CONSTRUCTION</u>	<u>SUBSTRATE</u>	<u>SPACER</u>	<u>DESICCANT</u>	<u>SEALANT</u>	<u>INTERNAL COMPONENTS</u>	<u>GCIA</u>
Gentek Building Products an Associated Materials Inc. Company 6320 Colonel Talbot Rd. London, ON N6P 1J1 Canada 519-652-3246 Gentek IGCC(R)/IGMA(R) 2382 + date	2382	BC3/MC1/MT	U/C3	FSF	IB	HM	BA	Yes
GLAAM (dba G-SMAT) Co., Ltd., (G-Frame) 298-42 Cheonbukjingang-ro Pyeongtaek-si, Gyeonggi-do 17800 South Korea +82-70-5106-2800	5613	MC4/PK	U/C3	PHF	LF	PIB/S2	GI	Yes
GLASPRO 9401 Ann Street Santa Fe Springs, CA 90670 USA 562-777-4148	4421	MC4/PK	U/C2	AA	LF	PIB/S2		
Glass and Mirror Craft PO Box 930439 Wixom, MI 48393 USA 2486246922 G&MC IGCC(R)/IGMA(R)22	4428 5049 5050 5432	BC4/PLC BC4/GSLC BC4/SSLC BC3/MC1/MT	U/C2 U/C2 U/C2 U/C2	AA SS PHSS FSF	LF LF LF IB	PIB/S2 PIB/S2 PIB/S2 HM	BA	Yes Yes Yes Yes
Glass Enterprises, Inc. 2277 New York Avenue Bensalem, PA 19020 USA 215-638-1007 BETA-PANE(R) IGCC(R)/IGMA(R) '22	3701 5269 5439 5440	BC4/GSLC BC4/GSLC BC3MC1/MT BC3/MC1/MT	U/C2 U/C2 U/C2 U/C2	AA AA FSF FSF	LF LF IB IB	PIB/PS2 PIB/S2 PIB/S2 PIB/PS2	BA	
Glass Insulators Inc. 600 Industrial Blvd Bloomer, WI 54724 USA 715-568-3649 GII IGCC(R)/IGMA(R) 2023	3144 3976	BC3/MC1/MT BC4/GSLC	U/C2/U U/C2/U	FSF/FSF MA/MA	IB/IB LF/LF	HM PIB/PS2	BA BA	Yes Yes
Glassbel Baltic 11, Pramonės Str. LT-94102 Klaipėda Lithuania +370-46-416380 GLASSBEL EN 1279 IGCC(R)/IGMA(R) + date + ID info	4729 4730	BC4/SSLC BC4/GSLC	U/C2/U U/C2/U	SS/SS PHSS/PHSS	LF/LF LF/LF	PIB/S2 PIB/S2		Yes Yes
GlassFab Tempering Services Inc. Holly Drive 4101 Holly Drive Tracy, CA 95376 209-229-1060 GlassFab IGCC®/IGMA® 22	2685	MC4/PK	U/C2	MA	LF	PIB/S2		

<u>LICENSEE</u>	<u>CERTIFICATION NUMBER</u>	<u>FRAME CONSTRUCTION</u>	<u>SUBSTRATE</u>	<u>SPACER</u>	<u>DESICCANT</u>	<u>SEALANT</u>	<u>INTERNAL COMPONENTS</u>	<u>GCIA</u>
Glassforms LLC DIP-1, Jabel Ali, Dubai Dubai 54226 United Arab Emirates 00971-4-8121251	5294	BC4/ALLC	U/C2	MA	LF	PIB/S2		Yes
Glasstech Industries B.S.C. PO Box No. 50968 Bahrain International Investment Park Building 325, Road No. 1506, Block-115 Hidd, Manama Bahrain +973 17464418	4925 5054	BC4/GSLC MC4/PK	U/C3 U/C2	MA SS	LF LF	PIB/S2 PIB/S2		
Glasswerks GWA- West 2323 Firestone Blvd. South Gate, CA 90280 USA 323-789-7800x351	2653 3727 3728 4023 4024 5763	BC4/GSLC/TI BC4/GSLC BC4/GSLC BC3/MC1/MT BC4/GSLC BC4/GSLC	U/C2 U/C2 U/C2 U/C2 U/C2 U/C2	AA MA AA FSF MA MA	LF LF LF IB LF LF	PIB/PS2 PIB/S2 PIB/S2 PIB/S2 PIB/PS2 PIB/S2		Yes Yes Yes Yes Yes Yes
Glasswerks GWLA- East 8600 Rheem Ave. South Gate, CA 90280 USA 323-789-7810	4340 5662 5792	BC4/GSLC BC4/GSLC BC3/MC1	U/C2 U U/C2	AA AA FSF	LF LF IB	PIB/S2 PIB/PS2 PIB/S2		
Glasswerks GWT 42005 Zevo Drive Temecula, CA 92590 USA 323-636-1906 GWT IGCC(R)/IGMA(R) 2022	4404 4902	MC4/PK MC4/PK	U/C2 U/C2	MA AA	LF LF	PIB/S2 PIB/S2	BA BA	Yes Yes
Glaz-Tech Industries, Inc. 6700 Bluewater Rd. NW Albuquerque, NM 87121 USA GTI 04 IGCC(R)/IGMA(R) '22	5774	MC4/PK	U/C2	AA	LF	PIB/PS2	BA	
Glaz-Tech Industries, Inc. 10757 North Dual Street Baton Rouge, LA 70814 USA 225-442-7040 GTI-09 IGCC(R)/IGMA(R) 22	4399	MC4/PK	U/C2	AA	LF	PIB/PS2	BA	
Glaz-Tech Industries, Inc. 1200 W Amity Road Boise, ID 83705-5413 USA 208-389-1080	3076	MC4/PK	U/C2	AA	LF	PIB/PS2	BA	

<u>LICENSEE</u>	<u>CERTIFICATION NUMBER</u>	<u>FRAME CONSTRUCTION</u>	<u>SUBSTRATE</u>	<u>SPACER</u>	<u>DESICCANT</u>	<u>SEALANT</u>	<u>INTERNAL COMPONENTS</u>	<u>GCIA</u>
Glaz-Tech Industries, Inc. 4005 S. Clay St. Englewood, CO 80110 USA 303-399-8587 GTI 07 IGCC(R)/IGMA(R) '22	3802 5678	MC4/PK MC4/PK	U/C2 U/C2	AA AA	LF LF	PIB/PS2 PIB/HM	BA BA	
Glaz-Tech Industries, Inc. 4931 W. Brill Street Phoenix, AZ 85043 USA (602) 272-1544 GTI-02 IGCC(R)/IGMA(R) 2022	5280	MC4/PK	U/C2	AA	LF	PIB/PS2	BA	
Glaz-Tech Industries, Inc. 2191 South 300 West, Suite # 5 Salt Lake City, UT 84115 USA 801-467-3136 GTI-06 IGCC(R)/IGMA(R) 2022	2330	MC4/PK/TI	U/C2	AA	LF	PIB/HM	BA	
Glaz-Tech Industries, Inc. 150 Industrial Rd. Santa Teresa, NM 88008 USA 505-589-4970 GTI03 IGCC(R)/IGMA(R) 22	5482	MC4/PK	U/C2	AA	LF	PIB/PS2	BA	
Glaz-Tech Industries, Inc. 2207 East Elvira Road Tucson, AZ 85745 USA 520-629-0268 GTI-01 IGCC(R)/IGMA(R) 23	2920 5693	MC4/PK MC4/PK	U/C2 U/C2	AA AA	LF LF	PIB/HM PIB/PS2	BA BA	
Glenny Glass Co. 205 Castleberry Court Milford, OH 45150 USA 513-489-2233 GLG IGCC(R)/IGMA(R) 22	2427 5386 5387	BC4/PK MC4/PK MC4/PK	U/C1 U/C2 U/C2	MA MA PHSS	LF LF LF	PIB/PS2 PIB/S2 PIB/S2	BA BA BA	 Yes Yes
Global Security Glazing 616 Selfield Road Selma, AL 36703 USA 334-875-1900 GSG IGCC(R)/IGMA(R) 2022	3711 5320 5322 IN 5323	MC4/PK MC4/PK MC4/PK MC4/PK	U/C2 U/C2 U/C2 U/C2	MA SS PHSS AA	LF LF LF LF	PIB/S2 PIB/S2 PIB/S2 PIB/S2		
GnT Glass Co., Ltd. District A, St 1, Ring 3 Huaxia Industrial Zone, Qiatou Dongguan, Guangdong Province 523532 China +86-138-2373-5541	3791 4591 5028	BC4/GSLC BC4/GSLC MC4/PK/PT/AP	U/C2 U/C2/U U/C2	MA MA/MA SS	LF LF/LF LF	PIB/S2 PIB/S2 PIB/S2		

<u>LICENSEE</u>	<u>CERTIFICATION NUMBER</u>	<u>FRAME CONSTRUCTION</u>	<u>SUBSTRATE</u>	<u>SPACER</u>	<u>DESICCANT</u>	<u>SEALANT</u>	<u>INTERNAL COMPONENTS</u>	<u>GCIA</u>
Greaney Glass Products Ltd Carnmore Oranmore, Co Galway H91 R6E Ireland 00353 91 794 381	5476	BC4/PLC	U/C2	PHSS	LF	PIB/PS2	BA	Yes
Grupo Vidrios el Castillo Avenida Las Industrias #500 Escobedo, Nuevo Leon 66062 Mexico 81-8154-5600	3516	BC4/SSLC	U/C2	MA	LF	PIB/S2		
G-TECH Optoelectronics Corporation No. 99, Chung Hsin Rd. Tongluo Township, Miaoli County 36647 Taiwan 037-236-988	4228	BC4/PLC	U/C3	AA	LF	PIB/S2		
Guang Dong Kibing Energy Saving Glass Co., LTD Guangdong Silicon Industry Basement Lankou Town, Dongyuan County Heyuan City, Guangdong 517564 China +86-762-8807993	4806	BC4/GSLC	U/C2	AA	LF	PIB/S2		
Guangdong Haikong Special Glass Technology Co., Ltd. No. 23, Shihua Blvd West Xiangshui River Industrial Park, Daya Bay Huizhou, Guangdong Province 516083 China 075527633580 GUANGDONG HAIKONG ASTM E2190 '22 IGCC@/IGMA@	2614	BC4/GSLC	U/C2	AA	LF	PIB/S2		
Guangdong South Star Glass Limited No. 6 Tuoye Road Sanshui Central Industrial Zone Leping Town, Sanshui District Foshan, Guangdong 528137 China +86 134 2768 7966	5016	BC4/GSLC	U/C2	AA	LF	PIB/S2		
Gulf Glass Industries, LLC Industrial Area 13 PO Box 6022 University City Road Sharjah 6022 United Arab Emirates 971-65-385500 GGI IGCC/IGMA 2022	5438	BC4/ALLC	U/U	AA	LF	PIB/S2		
Hankuk Glass Industries, Inc. 17, Oehang 6-gil Gunsan-si, Jeollabuk-do 54007 South Korea 82-63 460 4521	2387	MC4/PK	U/C2	AA	LF	PIB/S2		

<u>LICENSEE</u>	<u>CERTIFICATION NUMBER</u>	<u>FRAME CONSTRUCTION</u>	<u>SUBSTRATE</u>	<u>SPACER</u>	<u>DESICCANT</u>	<u>SEALANT</u>	<u>INTERNAL COMPONENTS</u>	<u>GCIA</u>
Haojing Holdings Group Limited No. 366 HaiBao Binjiang Street NanTong City, Haimen District 226100 China +86-021-56391128	4989 5623	BC4/GSLC BC4/GSLC	U/C2 U/C2	AA PHSS	LF LF	PIB/S2 PIB/S2		Yes Yes
Hartung Glass Industries 2150 E. Raymond St. Phoenix, AZ 85040 USA 602-323-9400	5103 5588	MC4/PK BC4	U/C2/U U/C2	MA/MA RTP	LF/LF IB	PIB/S2 RTP/S2	BA BA	 Yes
Hartung Glass Industries 17830 West Valley Highway Tukwila, WA 98188 USA 800-552-2227	2494 4566 5041	BC4/GSLC/TI BC3/MC1/MT BC2/MC2/PK	U/C2/U U/C2 U/C2	MA/MA FSF PHSS	LF/LF IB LF	PIB/S2 PIB/S2 PIB/S2	BA BA BA	Yes Yes
Hartung Glass Industries 10450 SW Ridder Road Wilsonville, OR 97070 USA 503-682-3846	2671	BC3/MC1/MT	U/C2	FSF	IB	RHM	BA	Yes
Harvey Building Products 30 Jack's Bridge Road Londonderry, NH 03053-2145 USA 603-216-8400 HII-1 IGCC(R)/IGMA(R) Oct 10 2022 Unit #	2712 4559 4560 4845 5418	BC3/MC1/SS/AP BC3/MC1/SS BC3/MC1/SS BC3/MC1/SS BC3/MC1/SS	U/C2/U U/C2 U/C3 U/C2 U/C2/U	UT/UT UT UT US UT/UT	DM DM DM DM DM/DM	HM/RHM HM HM HM HM	BA BA BA BA BA	Yes Yes Yes Yes Yes
Harvey Building Products 7 LedgeWood Boulevard North Dartmouth, MA 02747 USA 508-998-9779 HII-3 IGCC(R)/IGMA(R) Date time	2719 3744 3842 4185 5419	BC3/MC1/SS/AP BC3/MC1/SS BC3/MC1/SS BC3/MC1/SS BC3/MC1/SS	U/C2/U U/C2 U/C2 U/C3 U/C2/U	UT/UT US UT UT UT/UT	DM/DM DM DM DM DM/DM	HM/RHM HM HM HM HM	BA BA BA BA BA	Yes Yes Yes Yes Yes
Innovative Glass Products LLC 1430 Bradley Lane Suite 102 Carrollton, TX 75007 USA 469-726-2662 IGP IGCC®/IGMA® MM/DD/YYYY (glass etch)	4922 5576	BC3/MC1/MT BC3/MC1	U/C2 U/C2	FSF BFS	IB IB	RHM BFS	BA	
Insulite Glass Co., Inc. 780 W. Frontier Circle PO Box 2803 Olathe, KS 66063-0803 USA 913-780-2233	1702 3281	BC4/GSLC BC4/GSLC	U/C1 U/C1	MA PHSS	LF LF	PIB/S2 PIB/S2	BA BA	Yes Yes

<u>LICENSEE</u>	<u>CERTIFICATION NUMBER</u>	<u>FRAME CONSTRUCTION</u>	<u>SUBSTRATE</u>	<u>SPACER</u>	<u>DESICCANT</u>	<u>SEALANT</u>	<u>INTERNAL COMPONENTS</u>	<u>GCIA</u>
Interpane Glasgesellschaft, mbH - Lauenforde	4508	BC4/SSLC	U/C3/U	SS/SS	LF/LF	PIB/S2		Yes
SohnreysstraBe, 21 Lauenforde 37697 Germany	4509	BC4/SSLC	U/C3/U	PHSS/PHSS	LF/LF	PIB/S2		Yes
49-1609-728-7363	4510	BC4/ALLC	U/C3/U	MA/MA	LF	PIB/S2		Yes
Interpane 2 + Date +IGCC(R)/IGMA(R) +Cert# + Glass Info	4511	BC4/ALLC	U/C3/U	MA/MA	LF/LF	PIB/PS2		Yes
	5452	BC3/MC1/MT	U/C3	FSF	IB	PIB/S2		Yes
	5453	BC3/MC1/MT	U/C3/U	FSF/FSF	IB/IB	PIB/S2		Yes
Interpane Glasgesellschaft, mbH - Plattling	4034	BC4/SSLC	U/C3/U	SS/SS	LF/LF	PIB/S2		Yes
Robert Bosch Strasse, 2 Plattling, Germany 94447	4035	BC4/PLC	U/C3/U	PHSS	LF	PIB/S2		Yes
Germany	4044	BC4/ALLC	U/C3/U	MA/MA	LF/LF	PIB/PS2		Yes
49-9931-950-0	4045	BC4/ALLC	U/C3/U	MA/MA	LF/LF	PIB/S2		Yes
Interpane+plant ID+ date +IGCC(R)/IGMA (R)+cert# ++	4882	BC3/MC1/MT	U/C3	FSF	IB	PIB/S2		Yes
	5639	BC3/MC1/MT	U/C3/U	FSF/FSF	IB/IB	PIB/S2		Yes
Intigral	3027	BC3/MC1/MT	U/C3/U	FSF/FSF	IB/IB	HM	BA	Yes
6750 Vistoria East Austintown, OH 44515 USA	3028	BC3/MC1/MT	U/C3/U	FSF/FSF	IB/IB	HM	BA	Yes
330-793-7677	4627 IN	BC4/SS	U/C2/U	US/US	DM/DM	RHM	BA	Yes
INT AT IGCC(R)/IGMA(R) mm/dd/yy	4686 IN	BC3/MC1/SS	U/C3	UT	DM	RHM	BA	Yes
	5745	BC3/MC1/ZS	U/C3/U	UT/UT	DM/DM	HM	BA	Yes
	5746	BC3/MC1/ZS	U/C3/U	US/US	DM/DM	HM	BA	Yes
Intigral	3982	BC3/MC1/ZS	U/C3/U	US/US	DM/DM	HM	BA	Yes
480 California Road Quakertown, PA 18951 USA	4093	BC3/MC1/ZS	U/C3/U	UT/UT	DM/DM	HM	BA	Yes
215-538-9424	4094	BC3/MC1/ZS	U/C3/U	UT/UT	DM/DM	HM	BA	Yes
INTIGRAL QT IGCC (R)/ IGCC (R) mm/dd/year	4648	BC3/MC1/ZS	U/C3/U	US/US	DM/DM	HM	BA	Yes
	4673	BC3/MC1/MT	U/C3/U	FSF/FSF	IB/IB	HM	BA	Yes
	5538 IN	BC3/MC1/ZS	U/C3/U	US/US	DM/DM	RHM	BA	Yes
Intigral	4689	BC3/MC1/SS/TI	U/C3	US	DM	RHM/RHM	BA BL	Yes
9280 Dutton Drive Twinsburg, OH 44087 USA	5595	BC3/MC1/MT	U/C2/U	FSF/FSF	IB/IB	RHM	BA	Yes
440-317-0715	5596	BC3/MC1/MT	U/C2/U	FSF/FSF	IB/IB	RHM	BA	Yes
INT TB IGCC(R)/IGMA(R) mm/dd/yy								
Intigral	3921 IN	BC3/MC1/SS	U/C3/U	US/US	DM/DM	RHM	BA	Yes
7850 Northfield Rd. Walton Hills, OH 44146 USA	3922 IN	BC3/MC1	U/C3/U	UT/UT	DM/DM	RHM	BA	Yes
440-439-0980	4052	BC3/MC1/MT	U/C3/U	FSF/FSF	IB/IB	RHM	BA	Yes
Intigral WH IGCC(R)/IGMA(R) mm/dd/yy	5747	BC3/MC1/ZS	U/C3/U	UT/UT	DM/DM	HM	BA	Yes
	5748	BC3/MC1/ZS	U/C3/U	US/US	DM/DM	HM	BA	Yes
Isam M. Khairi Kabbani Glass Works LLC Jeddah 3rd Industrial City Jeddah, Mecca 22772 Saudi Arabia +966126278877 IKK IGCC®/IGMA® 2022	5240	BC4/GSLC	U/C2	MA	LF	PIB/S2		

<u>LICENSEE</u>	<u>CERTIFICATION NUMBER</u>	<u>FRAME CONSTRUCTION</u>	<u>SUBSTRATE</u>	<u>SPACER</u>	<u>DESICCANT</u>	<u>SEALANT</u>	<u>INTERNAL COMPONENTS</u>	<u>GCIA</u>
Isoclima Specialty Glass, LLC 520 East Chestnut St. P O Box 510 Blairsville, PA 15717 USA 724-459-9540 Dlubak IGCC (R)/IGMA (R) 2022	4958 5223 5288	MC4/PK MC4/PK MC4/PK	U/C2 U/C2 U/U	AA PHSS SS	LF LF LF	PIB/S2 PIB/S2 PIB/S2		
ITI Glass Company 4747 N. Webb Road Bel Aire, KS 67226 USA 316-262-7411	5646	BC4/GSLC	U/C2	AA	LF	PIB/S2	BA	
Jasan Glass - JSG 459-1 Neojo-Ri, Jori-Eup Paju, Gyeonggi 413-821 South Korea 82-31-941-6289	2275	BC4/SSLC	U/C2	PHSS	LF	PIB/S2		Yes
Jersey Tempered Glass, Inc. 2035 Briggs Rd. Mt. Laurel, NJ 08054 USA 856-273-8700 JTG IGCC(R)/IGMA(R) 22	689 750	MC4/PK MC4/PK	U/C1 U/C1	AA AA	LF LF	PU2 PIB/PU2		
Jiangmen Junfa Safety Glass Co., Ltd. 49 Gangzhou Avenue East Huicheng, Xinhui District Jiangmen, Guangdong 529100 China 0750-6165699	5291	BC4/GSLC	U/U	AA	LF	PIB/S2		
Jingmei Curtain Wall Technology Co., Ltd. North of Weiyi Road Yanjin County Textile Industrial Park Xinxiang, Henan 453000 China +86 18637395700	5159	BC4/GSLC	U/C2	AA	LF	PIB/S2		Yes
Jinzhou Fortune Spring Glass Co., Ltd. Wuyi Mountain Road #2 Binhai New District Jinzhou, Liaoning 121007 China 86-416-3581084 IGCC@IGMA@ 2811 06/2022	2811 2813 4906	BC3/MC1 BC3/MC1/TI BC3/MC1	U/U U/U U/C2	BCS BCS BCS	IB IB IB	BCS/PS2 BCS/PS2 BCS/PS2	GI GI GI	
Jiuh Sheng Glass Co., Ltd. No. 19, Zhongxing Road New Taipei City 236, Tucheng District 23678 Taiwan 886-2-2267-4929-225	4310	BC3/MC1/PK	U/U	AA	LF	PIB/S2		

<u>LICENSEE</u>	<u>CERTIFICATION NUMBER</u>	<u>FRAME CONSTRUCTION</u>	<u>SUBSTRATE</u>	<u>SPACER</u>	<u>DESICCANT</u>	<u>SEALANT</u>	<u>INTERNAL COMPONENTS</u>	<u>GCIA</u>
Kenyon's Stained Glass Factory, LLC. 5720 North Meadows Drive Grove City, OH 43123 USA 614-539-8740 ODL (K) IGCC(R)/IGMA(R) YYYY, Date	3680 4359	MC4/PK BC3/MC1	U/C2 U/C2	AA FSF	LF IB	PU2 PU2	BA GI BA GI	
La Tecnica Nel Vetro SpA Via. Domenico Catalano 88 Scafati, Salerno 84018 Italy 39-392-771-2550	4544 4545 4998 5112 IN	BC4/SSLC/AP BC4/SSLC BC4/SSLC BC4/SSLC	U/C2/U U/C2/U U/C2 U/C2	PHSS/PHSS PHSS/PHSS PHSS AA	LF LF LF LF	PIB/S2 PIB/PS2 PIB/S2 PIB/S2		Yes Yes Yes Yes
Laurier Architectural, Inc. 153 Laurier Blvd., #300 Laurier-Station, QC G0S 1N0 Canada 418-728-2023 IGCC(R)/IGMA(R) (cert#) Laurier (DD/YY)	2559 2629 5151 5152	MC4/PK MC4/PK MC4/PK MC4/PK	U/C2/U U/C2/U U/C2/U U/C2/U	PHSS/PHSS PHSS/PHSS PHF/PHF PHF/PHF	LF/LF LF/LF LF/LF LF/LF	PIB/PS2 PIB/S2 PIB/PS2 PIB/S2	BA BA	Yes Yes Yes
Louisville Plate Glass 4301 Chefs Way Louisville, KY 40218 USA 502-584-6145 LPG IGCC(R)/IGMA(R) 2022	1281 5664	BC4/GSLC BC4/GSLC	U/C2 U/C1	AA AA	LF LF	PIB/S2 PIB/PS2		
LTI Smart Glass, Inc. 14 Federico Drive Pittsfield, MA 01201 USA 413.637.5001 LTI IGCC(R)/IGMA(R) 2022	4904 4930 5556	BC3/MC1/MT BC4/GSLC BC4/SSLC	U/C2 U/C2 U/C2	FSF MA PHSS	IB LF LF	RHM PIB/RHM PIB/HM		
M Industria S.A. DE C.V. Motul, Km 10 Parcela 273 Z8 P1/1 Carretera Merida Conkal, Yucatán 97345 Mexico +52-999-930-23-70 SGCC label + M Industrias - Conkal IGCC@IGMA@2022	5114	BC3/MC1	U/C2	RTP	IB	RTP/S2		Yes
Mannix Exterior Wall Systems, Inc. 345 Crooked Hill Road Brentwood, NY 11717 USA 631-231-0800 MANNIX IGCC@IGMA@ 1746 2022	1746	MC4/PK	U/C2	AA	LF	PIB/PU2		
Maryland Glass & Mirror 710 W. Ostend St. Baltimore, MD 21230 USA 8003523380 Maryland Glass IGCC (R)/IGMA(R) '22	5324	BC4/SSLC	U/C2	AA	LF	PIB/S2		

<u>LICENSEE</u>	<u>CERTIFICATION NUMBER</u>	<u>FRAME CONSTRUCTION</u>	<u>SUBSTRATE</u>	<u>SPACER</u>	<u>DESICCANT</u>	<u>SEALANT</u>	<u>INTERNAL COMPONENTS</u>	<u>GCIA</u>
Megaluminio Servicios S. A. de C.V. DBA Megaglass Autopista Toluca-Atzacomulco KM 58.3 Atzacomulco, State of Mexico 50454 Mexico 7126901001	5491	BC4/GSLC/TI	U/C2	AA	LF	PIB/S2		
Mid-American Glass 147 S. Sturdevant St. PO Box 3428 Davenport, IA 52808-3428 USA 563-326-6294 Mid American Glass INC IGCC®/IGMA® 2022-2	2315 5325	MC4/PK MC4/PK	U/C2 U/C2	AA AA	LF LF	PIB/RHM PIB/S2	BA BA	Yes Yes
Midwest Glass Fabricators Inc. PO Box 1509 Highland, MI 48357 USA	5724 5726	BC4/GSLC BC4/GSLC	U/C2 U/C2	MA MA	LF LF	PIB/PS2 PIB/S2		Yes Yes
Nashville Tempered Glass LLC 1241 Avondale Dr. Hendersonville, TN 37075 USA 615-826-5522 NTGC IGCC(R)/IGMA(R) 2022	3991 4287 5060 5526	BC4/GSLC BC4/GSLC BC4 MC4/PK	U/C2 U/C1 U/C2 U/C2	MA AA RTP PHSS	LF LF IB LF	PIB/S2 PIB/S2 RTP/S2 PIB/S2	BA BA BA	Yes Yes Yes
Northwestern Glass Fab 5301 Industrial Blvd., NE Fridley, MN 55421 USA 763-762-1750 BV IGCC(R)/IGMA(R) '22	5354 5355	BC4/GSLC BC4/GSLC	U/C2 U/C2	MA MA	LF LF	PIB/PU2 PIB/S2	BA BA	
Northwestern Industries - Arizona, Inc. 7595 East 30th Street Yuma, AZ 85365-6532 USA (928) 726-3555 NWI Yuma, AZ IGCC(R)/IGMA(R) 2022	4754 5194 5600	BC4/GSLC BC4/GSLC BC4/GSLC	U/C2 U/C2 U/C2	PHSS MA MA	LF LF LF	PIB/S2 PIB/S2 PIB/S2		Yes Yes
Novatech Canada Inc. 100, 181e Rue Beauceville, QC G5X 2T1 Canada 418-774-2949 ext. 265 NovaTech YYYY-MM IGCC®/IGMA®	2877	BC3/MC1/MT	U/C2/U	FSF/FSF	IB/IB	HM		Yes
Novatech Patio Doors Ontario Inc. 500 Zenway Blvd Woodbridge, ON L4H 0S7 Canada 905-851-1006 Sunview Patio Doors IGCC(R)/IGMA(R) yyyy -mm-dd	3013	BC3/MC1/MT	U/C2/U	FSF/FSF	IB/IB	HM	BA	Yes

<u>LICENSEE</u>	<u>CERTIFICATION NUMBER</u>	<u>FRAME CONSTRUCTION</u>	<u>SUBSTRATE</u>	<u>SPACER</u>	<u>DESICCANT</u>	<u>SEALANT</u>	<u>INTERNAL COMPONENTS</u>	<u>GCIA</u>
Novavetro S.r.l. Via Ferrante Ferranti 35 Z.I. Taccoli San Severino Marche 62027 Italy +39 0733 64371	5160 5161 5211	MC4/PK MC4/PK MC4/PK	U/C3 U/C3 U/C3	MA PHSS AA	LF LF LF	PIB/S2 PIB/S2 PIB/PS2		Yes Yes Yes
ODL, Changshu ZhongXin Building Materials Co., Ltd. Meili Town Changshu, Jiangsu 215500 China 616-748-5401 ODL Inc.(ZX) IGCC®/IGMA® 22	3997 4195 4198	MC4/PK BC3/MC1 BC3/MC1	U/C2 U/C2 U/C2	AA BCS BCS	LF IB IB	PIB/PS2 BCS BCS/PS2	GI GI GI	
ODL, Inc. 215 E. Roosevelt Avenue Zeeland, MI 49464 USA 616-772-9111 ODL INC(Z)IGCC(R)/IGMA(R) 22	3052 4338 5504	BC3/MC1/SS/TI MC4/PK BC3/MC1	U/C2 U/C2 U/C2	UT AA BCS	DM LF IB	RHM PU2 BCS	BA BL BA BA	
ODL, Inc., Vidrio Decorativo Occidental S. A. de C. V. Poniente 4 Entre Norte 7 y Gral Pedro Hinojosa Ciudad Industrial Heroica Matamoros, Tamaulipas Mexico 616-772-9111 ODL Inc (V) IGCC®/IGMA® 22	3083 3309 4076 4141 4851 5207 5209 5651	MC4/PK MC4/PK/TI BC3/MC1/MT BC3/MC1 BC3/MC1 BC3/MC1 BC3/MC1/TI BC3/MC1	U/C2 U/C2 U/C2 U/C2 U/C2 U/C2 U/C2/U U/C2	AA AA FSF BCS BCS BCS UT/UT BCS	LF LF IB IB IB IB DM/DM IB	HM/PU2 PU2 HM BCS/PU2 BCS BCS RHM BCS	GI BA GI GI GI BA BA BL GI	
Oldcastle BuildingEnvelope® 5334 Barthel Industrial Drive, NE Albertville, MN 55301 USA 763-497-3212 OBE 22 IGCC(R)/IGMA(R) 2022	5346 5347	BC4/GSLC BC4/GSLC	U/C2 U/C2	MA PHSS	LF LF	PIB/S2 PIB/S2	BA BA	Yes Yes
Oldcastle BuildingEnvelope® 1611 S.E. Commerce Avenue Battle Ground, WA 98604 USA 360-816-7777 OBE 73 IGCC(R)/IGMA(R) 22	1537 2403 5479 5780	MC4/PK MC4/PK BC4 BC4	U/C2 U/C2 U U/C2	AA PHSS RTP RTP	LF LF IB IB	PIB/S2 PIB/S2 RTP/S2 RTP	BA BA	Yes Yes Yes Yes
Oldcastle BuildingEnvelope® 3601 - 72 Avenue SE Calgary, AB T2C 2K3 Canada 403-279-2544 Oldcastle 93 IGCC(R)/IGMA(R) '22	2703 2725 2878 2879 4700 4767 5483 5484	MC4/PK MC4/PK BC3/MC1/MT MC4/PK BC3/MC1/MT BC3/MC1 MC4/PK MC4/PK	U/C2/U U/C2/U U/C2/U U/C2/U U/C2/U U/C2/U U/C2/U U/C2/U	SS/SS PHSS/PHSS FSF/FSF AA/AA FSF/FSF FSF/FSF PHSS AA/AA	LF/LF LF/LF IB/IB LF/LF IB/IB IB/IB LF LF/LF	PIB/S2 PIB/S2 RHM PIB/S2 PIB/S2 PIB/S2 PIB/S2 PIB/S2	BA BA BA BA BA BA BA BA	Yes Yes Yes Yes Yes Yes Yes Yes

<u>LICENSEE</u>	<u>CERTIFICATION NUMBER</u>	<u>FRAME CONSTRUCTION</u>	<u>SUBSTRATE</u>	<u>SPACER</u>	<u>DESICCANT</u>	<u>SEALANT</u>	<u>INTERNAL COMPONENTS</u>	<u>GCIA</u>
Oldcastle BuildingEnvelope® 4161 S Morgan St. Chicago, IL 60609 USA 773-523-8400 OBE 24 IGCC(R)/IGMA(R) '22	1986	MC4/PK	U/C1	AA	LF	RHM	BA	
	4830	MC4/PK	U/C3	AA	LF	PIB/RHM	BA	
Oldcastle BuildingEnvelope® 2195 Langstaff Rd. Concord, ON L4K 2B2 Canada 905-660-3809 OLDCASTLE B.E.94IGMA(R)IGCC(R)2022	4450	BC4/GSLC	U/C2/U	MA/MA	LF/LF	PIB/S2		Yes
	5178	BC4/GSLC	U/C2/U	PHSS/PHSS	LF/LF	PIB/S2		Yes
Oldcastle BuildingEnvelope® 14117 Industrial Park Blvd. Covington, GA 30014 USA 678-212-7700 OBM IGCC(R)/IGMA(R) 2022	5444	BC4	U/C2	RTP	IB	RTP/S2		Yes
	5680	BC4	U/C2	RTP	IB	RTP/S2		Yes
	914	BC4/SSLC	U/C2	MA	LF	PIB/S2	BA	Yes
Oldcastle BuildingEnvelope® 11205 E. 37th Avenue Denver, CO 80239 USA 303-371-5511 OBE 63 IGCC(R)/IGMA(R) '22	2689	MC4/PK/TI	U/C2/U	AA/AA	LF	PIB /S2	BA	Yes
	3488	MC4/PK/TI	U/C2	AA	LF	PIB/RHM	BA	
	3937	MC4/PK/TI	U/C2	PHSS	LF	PIB/S2	BA	Yes
	5068	BC3/MC1/MT/TI	U/C2	FSF	IB	RHM	BA	
Oldcastle BuildingEnvelope® 6850 Stevenson Blvd. Fremont, CA 94538 USA 510-651-2292 OBE 84 IGCC@/IGMA® 22	4336	MC4/PK/TI	U/C2	MA	LF	PIB/S2	BA	Yes
	5127	MC4/PK	U/C2	PHSS	LF	PIB/S2	BA	Yes
Oldcastle BuildingEnvelope® 1101 Fountain Parkway Grand Prairie, TX 75050 USA 972-647-4028 OBE 83 IGCC(R)/IGMA (R) 22	4438	MC4/PK	U/C2	MA	LF	PIB/S2	BA	Yes
Oldcastle BuildingEnvelope® 895 Motor Pkwy. PO Box 18039 Hauppauge, NY 11788-8839 USA 631-234-2200 OLDCASTLE 15 IGCC@IGMA® 2022	4326	MC4/PK	U/C2	PHSS	LF	PIB/S2	BA	Yes
	4562	MC4/PK	U/C2	MA	LF	PIB/S2	BA	
	5412	MC4/PK	U/C2	AA	LF	PIB/S2	BA	Yes
	5754	MC4/PK	U/C2	MA	LF	PIB/S2	BA	Yes
Oldcastle BuildingEnvelope® 4822 Southerland Houston, TX 77092 USA 713-353-5800 OBE 65S IGCC(R)/IGMA(R) 21	5494	BC3/MC1/MT	U/C2	FSF	IB	PIB/S2		

<u>LICENSEE</u>	<u>CERTIFICATION NUMBER</u>	<u>FRAME CONSTRUCTION</u>	<u>SUBSTRATE</u>	<u>SPACER</u>	<u>DESICCANT</u>	<u>SEALANT</u>	<u>INTERNAL COMPONENTS</u>	<u>GCIA</u>
Oldcastle BuildingEnvelope® 8441 Bearing Dr. Indianapolis, IN 46268 USA 317-876-1155 OBE 29 IGCC(R)/IGCC(R) 22	4886	MC4/PK	U/C2	PHSS	LF	PIB/S2	BA	Yes
	653	MC4/PK	U/C2	MA	LF	PIB/S2	BA	Yes
Oldcastle BuildingEnvelope® 5075 275th Street Langley, BC V4W 0A8 Canada 604-607-1300 OBE 91 IGCC(R)/IGMA(R) '22	4256	MC4/PK	U/C2/U	MA/MA	LF/LF	PIB/S2	BA	Yes
	5229	MC4/PK	U/C2/U	PHSS/PHSS	LF/LF	PIB/S2	BA	Yes
	5735	BC4	U/C2	RTP	IB	RTP/S2		Yes
	5736	BC4	U/C2	RTP	IB	RTP/S2		Yes
Oldcastle BuildingEnvelope® 5631 Ferguson Dr. Los Angeles, CA 90022 USA 323-887-6000 Oldcastle 74 IGCC(R)/IGMA(R) 22	3303	MC4/PK/TI	U/C2	MA	LF	PIB/S2	BA	Yes
	4518	MC4/PK	U/C2	PHSS	LF	PIB/S2	BA	Yes
	5406	BC4	U	RTP	IB	RTP/S2		Yes
Oldcastle BuildingEnvelope® 220 NE 187th St. Miami, FL 33179 USA OBE 82 IGCC(R)/IGMA(R) 2022	3580	MC4/PK	U/C2	MA	LF	PIB /S2	BA	
Oldcastle BuildingEnvelope® 1500 Glen Ave. Moorestown, NJ 08057 USA 856-234-9222 Oldcastle 12 IGCC(R)/IGCC(R) '22	4976	BC4/GSLC	U/C2	AA	LF	PIB/S1		Yes
	5643	BC3/MC1/MT	U/C2	FSF	IB	PIB/S2		Yes
	5644	BC4/GSLC	U/C2	AA	LF	PIB/S2		Yes
Oldcastle BuildingEnvelope® Ampoint Industrial Park 291 "M" Street Perrysburg, OH 43551 USA 419-666-2000 OBE 81 IGCC(R)/IGMA(R) '22	2642	BC4/SSLC	U/C2	PHSS	LF	PIB/S2		Yes
	3262	BC4/SSLC	U/C2	MA	LF	PIB/S2		Yes
	5174	BC4	U/C2	RTP	IB	RTP/S2		Yes
	5682	BC4	U/C2	RTP	IB	RTP/S2		Yes
Oldcastle BuildingEnvelope® 3404 W. Papago Street #1 Phoenix, AZ 85009 USA 602-253-6980 OBE 63 IGCC(R)/IGMA(R) '22	4608	MC4/PK	U/C2	MA	LF	PIB/S2	BA	Yes
	4838	BC3/MC1/MT	U/C2	FSF	IB	PIB/S2		
Oldcastle BuildingEnvelope® 1900 Midland Street Rock Hill, SC 29731 USA 803-366-5167 Oldcastle BE 44 IGCC(R)/IGMA(R) 22	5393	BC4	U/C2	RTP	IB	RTP/S2		Yes
	5567	MC4/PK	U/C2	MA	LF	PIB/RHM		
	5568	MC4/PK	U/C2	MA	LF	PIB/S2	BA	
	5681	BC4	U/C2	RTP	IB	RTP/S2		Yes

<u>LICENSEE</u>	<u>CERTIFICATION NUMBER</u>	<u>FRAME CONSTRUCTION</u>	<u>SUBSTRATE</u>	<u>SPACER</u>	<u>DESICCANT</u>	<u>SEALANT</u>	<u>INTERNAL COMPONENTS</u>	<u>GCIA</u>
Oldcastle BuildingEnvelope® 5103 Janice Avenue Schofield, WI 54476 USA 715-359-2432 Oldcastle 27 IGCC®/IGMA® + date code	1312 1319 2583 2647 3337 3338	MC4/PK MC4/PK MC4/PK MC4/PK MC4/PK MC4/PK	U/C2/U U/C2/U U/C2/U U/C2/U U/C2/U U/C2/U	AA/AA AA/AA PHSS/PHSS PHSS/PHSS MA/MA MA/MA	LF/LF LF/LF LF/LF LF/LF LF/LF LF/LF	PIB/PU2 PIB/S2 PIB/S2 PIB/PU2 PIB/PU2 PIB/S2	BA BA BA BA BA BA	Yes Yes Yes Yes Yes Yes
Oldcastle BuildingEnvelope® 5115 East Hartford St. Tampa, FL 33619 USA 813-247-3184 OBE 43 IGCC (R)/IGMA (R) 2022	3621	MC4/PK	U/C2	MA	LF	PIB/S2	BA	
Oldcastle BuildingEnvelope® 1700 Daniel Boone Industrial Parkway Warrenton, MO 63380 USA 636-456-3452 OBE 21 IGCC®/IGMA® '22	3878 4036	MC4/PK MC4/PK	U/C2 U/C2	MA PHSS	LF LF	PIB/S2 PIB/S2	BA	Yes Yes
Oldcastle BuildingEnvelope® 30 Cooperative Way Wright City, MO 63390 USA 636-745-3030 OBE35 IGCC®/IGMA® + date. Printed on spacer at bender	2400 2893	BC4/GSLC/TI BC4/GSLC/TI	U/C2/U U/C2/U	PHSS/PHSS MA/MA	LF/LF LF/LF	PIB/S2 PIB/S2		Yes Yes
Oldcastle BuildingEnvelope® Canada Inc. 12755 boul Industriel Pointe-aux-Trembles, QC H1A 4Z6 Canada 514-640-5355 OLDCASTLE 95 MONTREAL IGCC(R)IGMA (R)2022	2883 2884 4855 5657 5658 5679	MC4/PK MC4/PK MC4/PK BC4 BC4 BC4	U/C2/U U/C2 U/C2/U U/C2 U/C2 U/C2	AA/AA PHSS PHSS/PHSS RTP RTP RTP	LF/LF LF LF/LF IB IB IB	PIB/S2 PIB/S2 PIB/S2 RTP/S2 RTP/S2 RTP/S2		Yes Yes Yes Yes Yes Yes
Opulux Glass 905 Murray Road East Hanover, NJ 07936 USA 973-795-0105	5624	BC4/GSLC	U/C2	MA	LF	PIB/PS2		
PA Glass Inc. 547 W Clearfield St. Philadelphia, PA 19133 USA 808-227-2722	5297	BC4/GSLC	U/C1/U	AA/AA	LF	PIB/S2	BA	
Panjin Truspacer Insulating Glass Material Co., Ltd. 585 Xingsheng Road Dawa Town Panjin, Liaoning 12400 China 86-427-6852078	5175	BC3/MC1	U/U	BCS	IB	BCS/PS2		Yes

<u>LICENSEE</u>	<u>CERTIFICATION NUMBER</u>	<u>FRAME CONSTRUCTION</u>	<u>SUBSTRATE</u>	<u>SPACER</u>	<u>DESICCANT</u>	<u>SEALANT</u>	<u>INTERNAL COMPONENTS</u>	<u>GCIA</u>
Patio Enclosures 720 East Highland Road Macedonia, OH 44056 USA 330-468-0700 PE IGCC(R)/IGMA(R) Date 'code'	1851	BC4	U/C1	FSF	IB	RHM		Yes
Pella Corporation 2000 Proline Place Gettysburg, PA 17325-8297 USA 717.334.0099 Pella G03 IGCC(R)/IGMA(R) + date	2688 4134 4932 5226 IN 5795	BC3/MC1/MT BC3/MC1/MT BC3/MC1/ZS BC3/MC1/ZS BC3/MC1/ZS	U/C2 U/C2 U/C2 U/C2 U/C2	FSF FSF US US US	IB IB DM DM DM	HM HM RHM RHM RHM	BA BA BA BA BA	Yes Yes Yes Yes Yes
Pella Corporation 111 Pella Place Macomb, IL 61455 USA 309-295-1407 IGCC(R)/IGMA(R) serial # NFRC# "date/time"	5020 5021 5756 5826	BC3/MC1/ZS BC4/PLC BC3/MC1/ZS BC3/MC1/MT	U/C2 U/C2 U/C2 U/C2	US SS US FSF	DM LF DM IB	RHM PIB/S1 RHM HM	BA BA BA BA	Yes Yes Yes Yes
Pella Corporation 307 Pella Way Murray, KY 42071 USA 270-767-2500 PELLA (date) (time) IGCC®/IGMA® NFRC #	4133 4657 4875 5227 IN 5518 5519 5520 IN 5557 IN 5666 5793 5794	BC3/MC1/MT BC4/PLC/TI BC3/MC1/ZS BC4/ZS BC4 BC4 BC4 BC4 BC3/MC1 BC3/MC1/ZS BC3/MC1/MT	U/C2 U/C2 U/C2 U/C2 U/C2 U/C2/U U/C2 U/C2 U/C2 U/C2 U/C2	FSF SS US US RTP RTP/RTP RTP RTP/RTP US US FSF	IB LF DM DM IB IB/IB IB IB/IB DM DM IB	HM PIB/S1 RHM RHM/HM RTP/PS2 RTP/PS2 RTP/S2 RTP/S2 RHM RHM HM	BA BA BA BA BA BA BA BA BA BA BA	Yes Yes/CPC Yes Yes Yes Yes Yes Yes Yes Yes Yes
Pella Corporation 18600 NE Wilkes Road Portland, OR 97230 USA 503-405-9176 Pella P52 IGCC(R)/IGMA(R) + date	4078 4103 4656 IN 4879 IN 4880 5326 5327	BC4/PLC/PA BC3/MC1/MT BC3/MC1/MT BC3/MC1/ZS/PA BC3/MC1/ZS/PA BC3/MC1/ZS/PA BC3/MC1/ZS	U/C2 U/C2 U/C2 U/C2 U/C2 U/C2 U/C2	SS FSF FSF US US US US	LF IB IB DM DM DM DM	PIB/S1 HM HM RHM/RHM RHM RHM/RHM RHM	BA BA BA BA BA BA BA	Yes Yes Yes Yes Yes Yes Yes
Pella Corporation 310 Rockingham Dr. Reidsville, NC 27320 USA 336-496-3325 Pella V02 date time IGCC(R)/IGMA(R)	5239	BC3/MC1/ZS	U/C2	US	DM	RHM	BA	Yes
Pella Corporation 1500 South Highway 59 Shenandoah, IA 51601 USA 712-246-6324 Pella IGCC®/IGMA® CIG 02.x (date)	4077	BC4/PLC	U/C2	SS	LF	PIB/S1	OI	Yes

<u>LICENSEE</u>	<u>CERTIFICATION NUMBER</u>	<u>FRAME CONSTRUCTION</u>	<u>SUBSTRATE</u>	<u>SPACER</u>	<u>DESICCANT</u>	<u>SEALANT</u>	<u>INTERNAL COMPONENTS</u>	<u>GCIA</u>
Pella Corporation 1800 North Main Avenue Sioux Center, IA 51250 USA 712-722-5609 Pella IGCC(R)IGMA(R) CIG-2 F "serial number" date	3291 4021	BC4/PLC/PA BC4/PLC	U/C2 U/C2	SS SS	LF LF	PIB/S1 PIB/S1	BA BA	Yes/CPC Yes
Pella Corporation 1501 Experiment Farm Road Troy, OH 45373 USA 937-875-4300 www.pella.comV04 IGCC(R)IGMA(R) + date	5478	BC3/MC1/ZS	U/C2	US	DM	RHM	BA	Yes
Perficom S.A. DE C.V. AV. Central No. 3 Fracc. Industrial Valle De Oro San Juan Del Rio, Queretaro 76803 Mexico 52-42 72 72 92 32	5014	BC3/MC1	U/C2	BPS	IB	BPS		Yes
PFG Glass 27413 55th Avenue Langley, BC V4W 3Y1 Canada 1-604-607-4500 PFG Glass IGCC(R)/IGMA(R) + Date	2470 3858 3859	BC3/MC1/MT/TI BC3/MC1/MT BC3/MC1/MT	U/C2/U U/C2/U U/C2/U	FSF/FSF FSF/FSF FSF/FSF	IB/IB IB/IB IB/IB	PIB/S2 HM PIB/HM	BA BA BA	Yes Yes Yes
Philly Glass Industry Inc. 7363 Tulip Street Unit B Philadelphia, PA 19136 USA 917-803-6883	5368	MC4/PK	U/C1	AA	LF	PIB/S2		
Pilkington IGP Sp. z.o.o. Branch Skierniewice, Poland ul. Przemyslowa 4 96-100 Skierniewice Poland 48-601-50-60-51 NSG IGCC(R)/IGMA(R) 22	4388 4389	BC4/GSLC BC4/GSLC/AP	U/C2 U/C2	PHSS PHSS	LF LF	PIB/S2 PIB/PU2	BA	Yes Yes
Pioneer Window Mfg. Corp. 200 Union Avenue PO Box 70 Johnstown, NY 12095 USA 518-762-5526	5318	MC4/PK	U/U	PHSS	LF	PIB/HM		
Piva Group North America LLC 5 Trautman Industrial Court Sainte Genevieve, MO 63670 USA 573-880-7133	5559 5560	BC3/MC1/MT BC3/MC1/MT	U/C3 U/C2	FSNF FSNF	IB IB	HM HM	BA BA	Yes Yes

<u>LICENSEE</u>	<u>CERTIFICATION NUMBER</u>	<u>FRAME CONSTRUCTION</u>	<u>SUBSTRATE</u>	<u>SPACER</u>	<u>DESICCANT</u>	<u>SEALANT</u>	<u>INTERNAL COMPONENTS</u>	<u>GCIA</u>
Precision Glass Industries 2330 Peyton Road Houston, TX 77032 USA 281-671-5221	5078	BC3/MC1/MT	U/C2	FSF	IB	PIB/S2		
	5665	BC3/MC1/AF	U/C2	FSF	IB	PIB/S2		
Prelco Inc. 94 Boulevard Cartier Postal Box 338 Riviere-du-loup, QC G5R 3Y9 Canada 418-862-2274 PRELCO INC IGCC(R)/IGMA(R) 22	1388	BC4/GSLC	U/C2	AA	LF	PIB/S2		Yes
	2270	BC4/GLSC	U/C2	PHSS	LF	PIB/S2		Yes
	2458	BC4/GSLC	U/C2	SS	LF	PIB/S2		Yes
	5420	BC4/GSLC	U/C2	SS	LF	PIB/S2		Yes
Prelco MTL Inc. 3740 Dollard-Desjardins Montreal, QC H1B 5X2 Canada 514-640-1122 PRELCO MTL IGCC(R)/IGMA(R) 2022	2491	BC4/GSLC	U/C2/U	AA/AA	LF/LF	PIB/S2		Yes
	3535	BC4/GSLC	U/C2	SS	LF	PIB/S2		Yes
	4746	BC4/GSLC	U/C2	PHSS	LF	PIB/S2		Yes
PRESS GLASS d.o.o Ulica dr. Marijana Mlinarića 5, Poduzetnička Zona Jalžabet Jalžabet 42203 Croatia +385 42 62 90 40	5554	BC4/SSLC	U/C2	MA/MA	LF/LF	PIB/PS2	BA	Yes
	5555	BC4/PLC	U/C2	PHSS	LF	PIB/PS2	BA	Yes
PRESS GLASS SP ZOO ul. Geodetow 4 Radomsko 97-500 Poland 48-44-685-87-00	4156	BC4/SSLC/AP	U/C2	GS	LF	PIB/S2	BA	Yes
	5023	BC4/SSLC/AP/PA	U/C2	SS	LF	PIB/PS2	BA	Yes/CPC
	5024	BC4/SSLC/AP	U/C2	GS	LF	PIB/PS2	BA	Yes
	5362	BC4/SSLC	U/C2/U	MA/MA	LF/LF	PIB/S2	BA	Yes
PRESS GLASS IGCC(R)/IGMA(R), Date, time, order number	5364	BC4/PLC/PA	U/C2/U	PHSS	LF	PIB/S2	BA	Yes/CPC
	5365	BC4/SSLC/PA	U/C2/U	MA	LF	PIB/PS2	BA	Yes/CPC
	5366	MC4/PK	U/C2/U	PHF/PHF	LF/LF	PIB/PS2		Yes
	5370	MC4/PK	U/C2/U	PHF	LF	PIB/S2		Yes/CPC
	5498	BC4/SSLC/PA	U/C2/U	PHSS/PHSS	LF/LF	PIB/PS2		Yes/CPC
	5499	BC4/SSLC/PA	U/C2/U	SS/SS	LF/LF	PIB/S2	BA	Yes/CPC
PRESS GLASS SP ZOO Ul Cielmicka Tychy 43-100 Poland 48-32-788-11-00	3742	BC4/SSLC/AP	U/C2	SS	LF	PIB/PS2		Yes
	3756	BC4/PLC/AP	U/C2	PHSS	LF	PIB/PS2		Yes
	3758	BC4/SSLC/AP	U/C2	GS	LF	PIB/PS2		Yes
	3760	BC4/SSLC/AP	U/C2	MA	LF	PIB/PS2		Yes
PRESS GLASS IGCC(R)/IGMA(R), Date, time, order number	4157	BC4/SSLC/AP	U/C2	MA	LF	PIB/S2		Yes
	4159	BC4/PLC/AP	U/C2	PHSS	LF	PIB/S2		Yes
	4161	BC4/SSLC/AP	U/C2	SS	LF	PIB/S2		Yes
	4162	BC4/SSLC/AP	U/C2	GS	LF	PIB/S2		Yes
	4703	MC4/AF	U/C2	FSF	IB	PIB/PS2		Yes
	4705	MC4/AF	U/C2	FSF	IB	PIB/S2		Yes

<u>LICENSEE</u>	<u>CERTIFICATION NUMBER</u>	<u>FRAME CONSTRUCTION</u>	<u>SUBSTRATE</u>	<u>SPACER</u>	<u>DESICCANT</u>	<u>SEALANT</u>	<u>INTERNAL COMPONENTS</u>	<u>GCIA</u>
Press Glass, Inc. Commonwealth Crossing Pkwy 1000 Ridgeway, VA 24148 USA 336-932-3666	5334 5335 5336 5397	BC4/GSLC BC4/GSLC BC4/GSLC BC4/GSLC	U/C2/U U/C2/U U/C2/U U/C2	SS/SS MA/MA PHSS/PHSS MA	LF LF LF LF	PIB/S2 PIB/S2 PIB/S2 PIB/S2		Yes Yes Yes Yes
Press Glass VA IGCC(R)/IGMA(R) 2022	5398 5399	BC4/GSLC BC4/GSLC	U/C2 U/C2	PHSS SS	LF LF	PIB/S2 PIB/S2		Yes Yes
Press Glass, Inc. 8901 US Highway 220 Bypass PO Box 938 Stoneville, NC 27048 USA 336-573-2393	3627 4604 5171 5866	BC4/GSLC BC4/SSLC BC4/SSLC LC	U/C2 U/C2 U/C2 U/C3	PHSS MA PHSS MA	LF LF LF LF	PIB/S2 PIB/S2 PIB/S2 PIB/S2		Yes Yes Yes
Press Glass IGCC(R)/IGMA(R) 2021								
PRL Glass Systems 13644 E Nelson Ave City of Industry, CA 91746 USA 626-961-5890	2906	MC4/PK	U/C2	MA	LF	PIB/S2	BA	
Procesadora De Jalisco S.A. DE C.V. - Queretaro Yaquis 10 Nuevo Parque Industrial San Juan del Rio, Queretaro 76806 Mexico 52 1427 121 0224	4680 4681	BC4/GSLC BC4/SSLC	U/C3 U/U	UT AA	DM LF	RHM PIB/S2		Yes Yes
Procesadora de Jalisco, S.A. DE C.V. Pedro Martinez Rivas #728 Col Parque Industrial Belenes Norte Zapopan, Jalisco 45150 Mexico (01 33) 3342 7979 CC2 5004 IGCC®/ IGMA® (Year)	5004	BC4/SSLC	U/C2	MA	LF	PIB/S2		
Productora y Distribuidora de Espejos S.A. de C.V. Carretera a Dulces Nombres Km. 10.5 Pesqueria, Nuevo Leon 66650 Mexico +52-81-1156-7000	5392	BC4/SSLC	U/C2	AA	LF	PIB/S2		
ProTemp Glass, Inc. 360 Applewood Crescent Concord, ON L4K 4V2 Canada 905-760-0701 IGCC®/IGMA® mm/dd/yyyy Protemp	5150 5193	BC4/GSLC BC4/GSLC	U/C2/U U/C2/U	PHSS/PHSS PHSS/PHSS	LF/LF LF/LF	PIB/S2 PIB/PS2		Yes Yes
Pulp Studio, Inc. 2100 West 139th Street Gardena, CA 90249 USA 310-815-4999 PULP STUDIO IGCC(R)/IGMA(R) 21	3589	MC4/PK	U/C2	SS	LF	PIB/S1		

<u>LICENSEE</u>	<u>CERTIFICATION NUMBER</u>	<u>FRAME CONSTRUCTION</u>	<u>SUBSTRATE</u>	<u>SPACER</u>	<u>DESICCANT</u>	<u>SEALANT</u>	<u>INTERNAL COMPONENTS</u>	<u>GCIA</u>
Qingdao Kingdom Glass Co., Ltd. North of the Southern Outer Ring No. 204 National Road Wangtai Town, Huangdao Qingdao, Shandong 266425 China +86 13695325318	5256	MC4/PK	U/C1/U	PHSS/PHSS	LF/LF	PIB/S2		Yes
Qinhuangdao High Tech Energy Saving Dorwin Co., Ltd. 1 Haihe Road E&T Development Zone Qinhuangdao City, Hebei 066004 China 00863358016100 Qinhuangdao High Tech IGCC®/IGMA® 2022	2595 2596 5380	BC3/MC1 MC4/PK MC4/PK	U/U U/C2 U/C2	BCS AA PHA	IB LF LF	BCS/PS2 PIB/PS2 PIB/PS2	GI BL BL	 Yes
Qinhuangdao Qicaishi Glass Processing Co., Ltd. 1/F, No.7 Songhuajiang West Road Economic and Technology Development Zone Qinhuangdao, Hebei 066004 China 86 335 5316825	5487 5744	BC3/MC1 BC3/MC1	U U/U	BCS BCS	IB IB	BCS/PS2 BCS/PS2	GI GI	
Qinhuangdao Qinsheng Glass Products Co., Ltd East of Chenguantun Village, Chenguantun Town Lulong County Qinhuangdao, Hebei 066000 China 86-18233561903	5500 5501 5502 5566	BC3/MC1 BC3/MC1 MC4/PK BC3/MC1	U/C2 U/C2 U/C2 U/C2	BCS BCS MA BCS	IB IB LF IB	BCS BCS/PS2 PIB/PS2 BCS/PS2	GI GI GI GI	
Qinhuangdao Rongsheng Glass Processing Co., Ltd. No. 3 Street, Sanjie Cunxi, Yanheying Town Lulong County Qinhuangdao, Hebei 066400 China 86.335.7179566 RSL IGCC®/IGMA® 4098 2022	4098 4671 4672 5477 5607 5608	BC3/MC1 BC3/MC1 MC4/PK BC3/MC1 BC3/MC1 BC3/MC1	U/C3 U/C3 U/C3 U/C2 U/C3 U/C3	BCS BCS MA BCS BCS BCS	IB IB LF IB IB IB	BCS/PS2 BCS PIB/PS2 BCS/PS2 BCS/PS2 BCS	GI GI GI GI GI GI	Yes
Qinhuangdao Shucheng Energy Saving Technology Co.,Ltd 4 Qilianshan Road Economic & Technical Development Zone Qinhuangdao, Hebei 066000 China 86-335-8503784 RSL IGCC®/IGMA® 4543 22	4543	MC4/PK	U/C2	AA	LF	PIB/PS2	BL	Yes

<u>LICENSEE</u>	<u>CERTIFICATION NUMBER</u>	<u>FRAME CONSTRUCTION</u>	<u>SUBSTRATE</u>	<u>SPACER</u>	<u>DESICCANT</u>	<u>SEALANT</u>	<u>INTERNAL COMPONENTS</u>	<u>GCIA</u>
Qinhuangdao Xinhua Glass Processing Ind. Co., Ltd. No. 5, Xihu Road Economic and Technical Development Zone Qinhuangdao, Hebei 066004 China 335-850-3784 IGCC®/IGMA® 2594 ASTM E2190 2022 08	2594 4495 4575 5535 5537 5737 5738	BC3/MC1 MC4/PK BC3/MC1 BC3/MC1 BC3/MC1 BC3/MC1 BC3/MC1	U/U U/C3 U/C3 U/U U/C1 U/C1 U/U	BCS AA BCS BCS BCS BCS BCS	IB LF IB IB IB IB IB	BCS/PS2 PIB/PS2 BCS/PS2 BCS/PS2 BCS BCS/PS2 BCS/PS2	GI BA GI GI GI GI GI	
Qinhuangdao Zhenhong Door and Window Co., Ltd. Fan Nan Village, Liushouying Town FuNing County Qinhuangdao, Hebei 066301 China 86-13785999021	4301 4490 4795	BC3/MC1 MC4/PK BC3/MC1	U/C3 U/C3 U/C3	BCS AA BCS	IB LF IB	BCS/PS2 PIB/PS2 BCS/PS2	GI BA GI	Yes Yes Yes
Quest USA, Inc. 1720 S. Jupiter Rd. Garland, TX 75042 USA 888-851-8588 Quest Windows USA IGCC®/IGMA® 2022	5142	BC4/GSLC	U/C2	PHSS	LF	PIB/PS2		Yes
Quest Window Systems 6811 Goreway Drive Mississauga, ON L4V 1L9 Canada 905-851-8588 QUEST WINDOWS IGCC(R)/IGMA(R) 2022	3860	BC4/SSLC	U/C2	PHSS	LF	PIB/PS2		Yes
Reem Emirates Aluminum & Glass ICAD-1 Musafah PO Box 36863 Abu Dhabi United Arab Emirates 0097125994301 REEM IGCC®/IGMA® 2022	4247	BC4/ALLC	U/U	MA	LF	PIB/S2		
Reflex d.o.o. Podgrad 4 Gornja Radgona 9250 Slovenija 00-386256-4503 Reflex d.o.o IGCC(R) / IGMA(R) 22	4695 4696	BC4/SSLC/AP BC4/SSLC/AP	U/C2 U/C2	PHSS PHSS	LF LF	PIB/PS2 PIB/S2		Yes Yes
SAAND Inc. 250 Brockport Dr. Toronto, Ontario, ON M9W5S1 Canada 4167982345 Saand Inc. IGCC(R)/IGMA(R) 2022	3724 4257 4639	BC4/GSLC BC4/GSLC BC4/GSLC	U/C2 U/C2 U/C2	SS MA PHSS	LF LF LF	PIB/S2 PIB/S2 PIB/S2		Yes Yes Yes

<u>LICENSEE</u>	<u>CERTIFICATION NUMBER</u>	<u>FRAME CONSTRUCTION</u>	<u>SUBSTRATE</u>	<u>SPACER</u>	<u>DESICCANT</u>	<u>SEALANT</u>	<u>INTERNAL COMPONENTS</u>	<u>GCIA</u>
SAGE Electrochromics Inc. Two Sage Way Faribault, MN 55021 USA 507-331-4848 SageGlass(R)SAINT-GOBAIN IGCC(R)IGMA (R) 22	4954	BC4/PLC/SP/TI	U/C2/U	SS/SS	LF/LF	PIB/S2	OI	Yes
Saint-Gobain India Private Limited Plot No. A-1 SIPCOT Industrial Park Sriperumbudur, Tamilnadu India 919840509386	4653 4669 5597	BC4/GSLC BC4/GSLC MC4/PK	U/C3 U/C3/U U/C3	AA MA/SS AA	LF LF/LF LF	PIB/S2 PIB/S2 PIB/S2		Yes
Saudi American Glass Company PO Box 8418 Riyadh 11482 Saudi Arabia 01-2651212 SAGCO IGCC®/IGMA® 2022	3274	BC4/SSLC	U/C3	MA	LF	PIB/S2		Yes
SEREX MULTIVITRUM srl Via del Commercio, 14/a Torviscosa 33050 Italy +39 0431929227	5645	BC4/SSLC/AP	U/C2	PHSS/PHSS	LF/LF	PIB/PS2	BA	
ShanDong HaanGlas Co., LTD No. 2 Dongyue Ave. Taishan District Tai'an, Shandong 271000 China 86-17705464660	5691 5692	VG BC4/GSLC	U/C2 U/C2/U	VG PHSS	Ba-Al Getter LF	VG PIB/S2	OI	Yes
Shandong Jinjing Science & Technology Stock Co., Ltd. Boshan Branch. West of Daqiao Village Economic and Technological Development Zone Boshan District Zibo City, Shandong Province 255200 China 0571-85119627	5430	BC4/GSLC	U/C2	AA	LF	PIB/S2		Yes
Shandong Yaohua Glass Co., Ltd. No. 7 Kaiyuan Road, Licheng Area Jinan, Shandong 250101 China 85-531-8880-2996	4539	BC4/GSLC	U/C2	AA	LF	PIB/S2		
Shanghai Lead Glass Co., Ltd. No. 88 West Heli Rd., Pudong Shanghai 201317 China 18637937146	4903	BC4/GSLC	U/C2	AA	LF	PIB/PS2		

<u>LICENSEE</u>	<u>CERTIFICATION NUMBER</u>	<u>FRAME CONSTRUCTION</u>	<u>SUBSTRATE</u>	<u>SPACER</u>	<u>DESICCANT</u>	<u>SEALANT</u>	<u>INTERNAL COMPONENTS</u>	<u>GCIA</u>
Shanghai SYP Engineering Glass 75 Kangliu Road Pudong New Area Pudong, Shanghai 201315 China 86-21-38108108 SYP IGCC@IGMA@ '22	2523 3231 3232 5690	BC4/GSLC BC4/GSLC BC4/GSLC BC4/GSLC	U/C2 U/C2 U/C2 U/C2/U	AA SS PHSS PHSS/PHSS	LF LF LF LF/LF	PIB/S2 PIB/S2 PIB/S2 PIB/S2		Yes Yes Yes Yes
Shenbo Special Architectural Glass Industrial Co., LTD Macau Industry Zone, Zhangge Village Guanlan Town Shenzhen, Guangdong China 86-852-21173390	2573 5617	BC4/GSLC BC4/GSLC	U/C2 U/C2	MA MA	LF LF	PIB/S2 PIB/S2		
Shengng Mwuh Enterprise Co., Ltd No. 51, Ln. 33 Zhunan Road Renwu District Kaohsiung City 81448 Taiwan 886-7-374-0888	4919	MC4/PK	U/U	AA	LF	PIB/S2		
ShenZhen LiaoYuan Glass Co., Ltd. Liaoyuan Industrial Area, Jinbei Villiage Shiyan Town, Baoan District Shenzhen, Guangdong 518108 China 86-13410765603	3833 5356	BC4/GSLC BC4/GSLC	U/C2 U/C2	MA MA	LF LF	PIB/PS2 PIB/S2		Yes Yes
Shenzhen Shennanyi Glass Product Co., Ltd 32 Makan South Road, Makan Village Xili Town, Nanshan District Shenzhen, Guangdong Province 518055 China 008675526012714	5695	BC4/GSLC	U	PHSS	LF	PIB/S2		
Shine Glass Co., Ltd. No. 3-1, Gongye 5th Road Pingzhen City Taoyuan County Taiwan China 886-3-469-1599	4013	MC4/PK	U/C3	AA	LF	PIB/S2		
Shinn Fu Pair Glass Co. No. 1-1, Wen Ming 3 Street Kweishan, Taoyuan, Taiwan China 886-3-3283226	1822	MC4/PK	U/U	AA	LF	PIB/S2		

<u>LICENSEE</u>	<u>CERTIFICATION NUMBER</u>	<u>FRAME CONSTRUCTION</u>	<u>SUBSTRATE</u>	<u>SPACER</u>	<u>DESICCANT</u>	<u>SEALANT</u>	<u>INTERNAL COMPONENTS</u>	<u>GCIA</u>
Sichuan CSG Energy Conservation Glass Co., Ltd. No. 16 Section 2 Huanglong Road The Southwest Airport Economic Development Zone Wuhou District Chengdu, Sichuan 610213 China +86 28 85689888	4883	BC4/GSLC	U/C2	AA	LF	PIB/S2		
Sierra Glass Fabrication Inc. 905 Linda Way Sparks, NV 89431 USA 775-355-0700	5699	BC4	U/C2	RTP	IB	RTP/S2	BA	Yes
Sierra Pacific Windows 575 S. Whelen Ave. Medford, WI 54451 USA (530) 528-3842 SPW67 IGCC® /IGMA® @ 22	4381	BC3/MC1/MT	U/C2/U	FSF/FSF	IB/IB	RHM	BA	Yes
Sierra Pacific Windows 11605 Reading Road PO Box 8489 Red Bluff, CA 96080 USA 530-527-9620 SPW66 IGCC(R)/IGMA(R) 2022	4283 5514	BC3/MC1/MT/T1 BC3/MC1/MT/T1/PA	U/C2/U U/C2	FSF/FSF FSF	IB/IB IB	RHM RHM	BA BA	Yes Yes/CPC
Sierra Pacific Windows - O 605 N. Ohio St. Merrill, WI 54452 USA 800-433-4873 SPW 62 IGCC®/IGMA® 22	5599	BC3/MC1	U/C2/U	FSF	IB	RHM	BA	Yes
Sierra Pacific Windows - W 1815 Water St. Merrill, WI 54452 USA 715-748-2011 SPW65 IGCC®/IGMA® coating/month/year	3653 3654 4625	MC4/PK BC3/MC1 BC3/MC1	U/C2 U/C2 U/C2	AA UT US	LF DM DM	PIB/HM HM HM	BA BA BA	Yes Yes Yes
SIGCO, Inc. 48 Spiller Drive Westbrook, ME 04092 USA 207-775-2676 SIGCO IGCC(R)/IGMA(R) Month/Year	2203 3131 5251	MC4/PK MC4/PK MC4/PK	U/C2 U/C2 U/C2	AA PHSS AA	LF LF LF	PIB/S2 PIB/S2 PIB/S2	BA BA BA	Yes Yes Yes
Skyland Insulated Glass Corp. 39-16 23rd Street Long Island City, NY 11101 USA 718-707-0288	4180	BC4/GSLC	U/C1	AA	LF	PIB/S2		

<u>LICENSEE</u>	<u>CERTIFICATION NUMBER</u>	<u>FRAME CONSTRUCTION</u>	<u>SUBSTRATE</u>	<u>SPACER</u>	<u>DESICCANT</u>	<u>SEALANT</u>	<u>INTERNAL COMPONENTS</u>	<u>GCIA</u>
Soluciones Vitro Plano S.A. de C.V. Av. Rio de los Remedios No. 1 Col San Juan Ixhuatepec Tlalnepantla de Baz 54180 Mexico 52-55-5227-6000/6055 PVA 4884 IGCC®/IGMA® 22 on spacer bar	4884	MC4/PK	U/C2	MA	LF	PIB/S2		
Stanley Glass Co., Ltd. No. 12, Wuxun Street Dawulun Industrial District Keelung 20446 Taiwan 886-2-2432-1288	4020 5718	MC4/PK BC4/GSLC	U/U U/U	MA AA	LF LF	PIB/S2 PIB/S2		
Stargrup Cam A.S. Hadimkoy Mah. Mustafa Inan Cad. No: 17 34555 Hadimkoy Arnavutkoy, Istanbul 34960 Turkey 90-212-771-38-18 Stargrup IGCC(R)/IGMA(R) 2022	4548 4549	MC4/PK MC4/PK	U/C2 U/C2	PHSS PHSS	LF LF	PIB/S2 PIB/S2		Yes
Strong Tempering Glass Industry LLC 530B 63rd Street Brooklyn, NY 11220 USA 718-765-0007	4520	MC4/PK	U/C1	AA	LF	PIB/S2		
Sunglas Technics Co., Ltd. No. 16 Fenghuang Dadao National Ecological Industrial Park Danzao Town, Nanhai Foshan, Guangdong Province 828216 China 86 18602033514	4961	BC4/GSLC	U/C2	AA	LF	PIB/S2		
Suzhou Taifeng Glass Decoration Co. Ltd No. 9 Jing'er Road, Development Zone Taicang, Jiangsu 215400 China 0086-512-53553995	3003 3808 5243	MC4/PK BC3/MC1 BC3/MC1/TI	U/C2 U/C2 U/U	AA BCS PHSS	LF IB LF	PIB/PS2 BCS PIB/S2	GI GI BL	
Syracuse Glass Company, LLC 1 General Motors Drive PO Box 381 Syracuse, NY 13206 USA 315-437-9971 SGC IGCC/IGMA 22	4371 4934 IN 5046 5096 IN 5428 823 828	BC4/GSLC MC4/PK BC4/GSLC MC4/PK BC4/GSLC BC4/GSLC BC4/GSLC	U/C2 U/C2 U/C2 U/C2 U/C2/U U/C2 U/C2	PHSS AA PHSS AA AA/AA AA AA	LF LF LF LF LF/LF LF LF	PIB/S2 PIB/S2 PIB/PS2 PIB/S2 PIB/S2 PIB/PS2 PIB/S2	BA OI BA BA BA BA BA	Yes Yes Yes Yes Yes Yes Yes
Tai Shan City Da Heng Art Glass Ltd. 1 Toi Hok Road, South Industrial Zone Shui Bu Town Tai Shan, Guangdong Province 529000 China 86-750-5456889	5667	BC3/MC1	U/U	BCS	IB	BCS	GI	

<u>LICENSEE</u>	<u>CERTIFICATION NUMBER</u>	<u>FRAME CONSTRUCTION</u>	<u>SUBSTRATE</u>	<u>SPACER</u>	<u>DESICCANT</u>	<u>SEALANT</u>	<u>INTERNAL COMPONENTS</u>	<u>GCIA</u>
Taiwan Glass Industry Corp. No. 261, Sec. 3, Nanking E. Road Taipei, Taiwan 105 China 886-2-27130333	2053 3805	MC4/PK MC4/PK	U/C2 U/C2	AA AA	LF LF	PIB/S2 PIB/S2		
Technical Glass & Aluminum Factory LLC Plot number# 594-7418 Jabel Ali Industrial Area Jabel Ali, Dubai United Arab Emirates 971552446070	5659	BC4/ALLC	U/C2	MA	LF	PIB/S2		Yes
Tecnoglass S.A.S. Avenida Circunvalar a 100 mts de la Via 40 Barrio Las Flores Barranquilla Colombia 57 5 373 4000	1393 1813 2683 4757 4941 4942	BC4/GSLC BC4/GSLC BC4/GSLC BC3/MC1 BC4/SSLC BC4/SSLC	U/C2 U/C2 U/C2 U/C2 U/C2 U/C2	MA MA SS FSF MA MA	LF LF LF IB LF LF	PIB/PS2 PIB/S2 PIB/S2 PS2 PIB/S2 PIB/S2		Yes Yes Yes
Tecnoglass SAS /IGCC®/IGMA®(#) ASTME 2190 CBA(Fab date)	4943 5348 5349	BC4/SSLC BC4/PLC BC4/GSLC	U/C2 U/C2 U/C2	SS PHSS PHSS	LF LF LF	PIB/S2 PIB/S2 PIB/S2		Yes Yes
Tecnovidrio S.A. de C.V. Cafetal 240 Colonia Granjas Mexico Delegacion Iztacalco, Mexico City 08400 Mexico 52-55-3000-2000 Grupo Tecnovidrio IGCC®/IGMA® 3754 (year)	3754	BC4/SSLC	U/C2	AA	LF	PIB/S2		
Temp Glass Inc. 12 Zane Grey El Paso, TX 79906 USA 915-274-1374 TEMP GLASS IGCC/IGMA 22	5264	MC4/PK	U/C2	AA	LF	PIB/S2		
Tempco Glass 131-10 Maple Ave. Flushing, NY 11355 USA 718-461-6888	4230 4496	MC4/PK MC4/PK	U/C2 U/C2	AA MA	LF LF	PIB/S2 PIB/S2	BA BA	Yes Yes
Templados Del Centro SA DE C.V. Carretera Irapuato-Silao km 13.5 Irapuato, Guanajuato Mexico 00152462 800 60 60	5569	BC4/SSLC	U/C2	MA	LF	PIB/S2		

<u>LICENSEE</u>	<u>CERTIFICATION NUMBER</u>	<u>FRAME CONSTRUCTION</u>	<u>SUBSTRATE</u>	<u>SPACER</u>	<u>DESICCANT</u>	<u>SEALANT</u>	<u>INTERNAL COMPONENTS</u>	<u>GCIA</u>
Templados Industriales S.A. de C.V. C. Erasmo Dominguez 12303 Nombre De Dios Chihuahua, Chihuahua 31105 Mexico 614-201-0490 Templados Industriales IGCC®/IGMA® 22	5241	BC4/SSLC	U/C2	MA	LF	PIB/S2		Yes
TG Taicang Architectural Glass Co. Ltd 9 ShenJiang Road Taicang Suzhou, Jiangsu China 86-512-57440001 TG Taicang IGCC®/IGMA® 2022	4972 4973	BC4/GSLC BC4/GSLC	U/C2/U U/C2	PHSS/PHSS AA	LF/LF LF	PIB/S2 PIB/S2		Yes Yes
TG Tianjin Glass Co., Ltd. No.5, Taian Road Jinghai Development Zone Jinghai, Tianjin 301609 China	5626 5627	BC4/GSLC BC4/GSLC	U/C2 U/C2	AA PHSS	LF LF	PIB/S2 PIB/S2		Yes Yes
Thermafix A.J. Inc. 1232, Route 111 E Amos, QC J9T 3A1 Canada 418-561-3073 PO#Therma ABI (YYYY/MM) IGCC®/IGMA®	5113 5222 5771	MC4/PK MC4/PK MC4/PK	U/C3/U U/C3/U U/C3/U	PHSS/PHSS PHF/PHF PHF/PHF	LF/LF LF/LF LF/LF	PIB/RHM PIB/RHM PIB/RHM	BA BA BA	Yes Yes Yes
Thermafix A.J. Inc. 63 Chemin St. Laurent Baie St. Paul, QC G3Z 2L5 Canada 418.668.6131 THERMA BSP (YYYYMMDD) IGCC/IGMA (DIM.) (Unit Spec.)	3764 5015 5191	MC4/PK MC4/PK MC4/PK	U/C3/U U/C3/U U/C3/U	PHSS/PHSS PHF/PHF PHSS/PHSS	LF/LF LF/LF LF/LF	PIB/RHM PIB/RHM PIB/RHM	BA BA BA	Yes Yes Yes
Thermafix A.J. Inc. 1396 Route du Rondin St. Nazaire, QC G0W 2V0 Canada 418-881-2303 PO#therma STN (YYYY/MM) IGCC/IGMA	5648 5649	MC4/PK MC4/PK	U/C3 U/C3	PHSS/PHSS PHF/PHF	LF/LF LF/LF	PIB/RHM PIB/RHM	BA BA	Yes Yes
Thermo BSL 141 Chemin des Raymond Riviere-du-loup, QC G5R 4L9 Canada 418-862-2611 Thermos BSL DD/MM/YY IGCC(R)/IGMA(R) lepage order code	3001	MC4/PK	U/C2/U	PHSS/PHSS	LF	PIB/RHM	BA	Yes

<u>LICENSEE</u>	<u>CERTIFICATION NUMBER</u>	<u>FRAME CONSTRUCTION</u>	<u>SUBSTRATE</u>	<u>SPACER</u>	<u>DESICCANT</u>	<u>SEALANT</u>	<u>INTERNAL COMPONENTS</u>	<u>GCIA</u>
Thompson I.G. LLC. 3196 Thompson Rd. Fenton Operation Fenton, MI 48430 USA 810-629-9558 TIG 2022 IGCC(R)/IGMA(R)	4977 5389 5532 5687	MC4/PK MC4/PK MC4/PK MC4/PK	U/C2 U/C2/U U/C2 U/C2/U	PHSS SS/SS MA PHSS/PHSS	LF LF/LF LF LF/LF	PIB/S2 PIB/S2 PIB/S2 PIB/S2	BA BA BA BA	Yes Yes Yes Yes
Tianjin CSG Energy Conservation Glass Co., Ltd No. 12 Quanfeng Road Tianjin New Technology Industrial Park Zones Wuqing District, Tianjin 301726 China 86-150-22345565	2276 2336 5132 5165	BC4/GSLC BC4/GSLC BC4/GSLC BC4/GSLC	U/C2 U/C2 U/C2 U/C2/U	AA AA PHSS PHSS/PHSS	LF LF LF LF/LF	PIB/S2 PIB/PS2 PIB/S2 PIB/S2		Yes Yes Yes Yes
Tianjin Northglass Industrial Technical Co., Ltd South of Baozhong Avenue West of Tianxing Road Energy Conservation & Environmental Protection Baodi District, Tianjin 301800 China 86-022-59281102 NorthGlass ASTM E2190 '22 IGCC®/IGMA®	3862 4999 5467	BC4/SSLC BC4/SSLC BC4/GSLC	U/C2 U/C2 U/U	PHSS PHSS MA	LF LF LF	PIB/S2 PIB/S2 PIB/S2		Yes
Tianjin SYP Engineering Glass Co., Ltd. 1 Huatai Road Beichen District, Tianjin 300409 China 86-22-86880204 SYP 03 IGCC®/IGMA® E2190 '22	2525 3026 3227 5602 5603	BC4/GSLC BC4/GSLC BC4/GSLC BC4/GSLC BC4/GSLC	U/C2 U/C2 U/C2 C2/U/U C2/U/U	AA SS PHSS AA/AA PHSS/PHSS	LF LF LF LF/LF LF/LF	PIB/S2 PIB/S2 PIB/S2 PIB/S2 PIB/S2		Yes Yes Yes Yes Yes
Tower Insulating Glass LLC. 2485 Charles Court Bellmore, NY 11710-2773 USA 516-887-3300 Tower Glass LLC IGCC(R)/IGMA(R) 1470 2022	1470 5173	MC4/PK BC3/MC1/MT	U/C3 U/C1	AA FSF	LF IB	PIB/S1 HM	BA BA	Yes Yes
Tristar Glass, Inc. 1120 West Main Pkway Catoosa, OK 74015 USA 918-392-9678 Tristar TUL IGCC(R)/IGMA(R) '22	2627	BC4/GSLC	U/C2	MA	LF	PIB/S2	BA	
Tristar Glass, Inc. 1790 Westpark Drive Grand Prairie, TX 75050 USA 817.262.5960 Tri Star DFW IGCC®/IGMA® '22	3594	BC4/GSLC	U/C2	MA	LF	PIB/S2		

<u>LICENSEE</u>	<u>CERTIFICATION NUMBER</u>	<u>FRAME CONSTRUCTION</u>	<u>SUBSTRATE</u>	<u>SPACER</u>	<u>DESICCANT</u>	<u>SEALANT</u>	<u>INTERNAL COMPONENTS</u>	<u>GCIA</u>
Tristar Glass, Inc. 19522 Aldine Westfield Houston, TX 77073 USA 281-960-6840 Tristar Hou IGCC(R)/IGMA(R) 22	4316	BC4/GSLC	U/C2	MA	LF	PIB/S2		
Trulite Glass and Aluminum Solutions 11950 E. 33rd Ave. Aurora, CO 80010 USA 303-340-4290 W-31 IGCC(R)/IGMA(R) 2023	4885	MC4/PK/TI	U/C2	MA	LF	PIB/PS2		
Trulite Glass and Aluminum Solutions 100 Business Center Drive Cheswick, PA 15024 USA 800-232-9050 Trulite W43 IGCC(R)/IGMA(R) 2022	3527	BC4/GSLC	U/C2	PHSS	LF	PIB/S2	BA	
	4636	BC4/GSLC	U/C2	MA	LF	PIB/S2	BA	
Trulite Glass and Aluminum Solutions 19430 E. San Jose Ave. City of Industry, CA 91748 USA 800-774-4224 Trulite W47 IGCC®/IGMA® 2022	4364	MC4/PK	U/C2	MA	LF	PIB/S2	BA	Yes
	4418	MC4/PK	U/C2	PHSS	LF	PIB/S2	BA	
	5845	MC4/PK	U/C2	PHSS	LF	PIB/S2	BA	Yes
Trulite Glass and Aluminum Solutions 4400 Cambridge Rd. Fort Worth, TX 76155 USA 817-785-1220 IGCC(R)/IGMA(R) Trulite W35 2023	5580	MC4/PK	U/C1	MA	LF	PIB/S2	BA	
Trulite Glass and Aluminum Solutions 3333 Holly Hall Houston, TX 77021 USA 713-747-5430 Trulite W46 IGCC(R)/IGMA(R) 2022	5525	MC4/PK	U/C2	MA	LF	PIB/S2	BA	
Trulite Glass and Aluminum Solutions 7701 W. New York St. Indianapolis, IN 46214 USA 800-876-0646 Trulite W-14 IGCC(R)/IGMA(R) 2022	5563	MC4/PK	U/C2	PHSS	LF	PIB/S2	BA	
	5612	MC4/PK	U/C2	MA	LF	PIB/S2	BA	
Trulite Glass and Aluminum Solutions 2522 Westcott Blvd. Knoxville, TN 37931 USA 865-691-2040 Trulite W63 IGCC(R)/IGMA(R) 2023	2220	MC4/PK	U/C2	MA	LF	PIB/S2	BA	Yes

<u>LICENSEE</u>	<u>CERTIFICATION NUMBER</u>	<u>FRAME CONSTRUCTION</u>	<u>SUBSTRATE</u>	<u>SPACER</u>	<u>DESICCANT</u>	<u>SEALANT</u>	<u>INTERNAL COMPONENTS</u>	<u>GCIA</u>
Trulite Glass and Aluminum Solutions 1513 North A St. Las Vegas, NV 89106 USA 702-385-3095	5429	MC4/PK	U/C2	MA	LF	PIB/S2	BA	
Trulite Glass and Aluminum Solutions 660 Campbell Court Lithia Springs, GA 30122 USA 770-434-2041 Trulite W74 IGCC(R)IGMA(R)2022	4488 4489 4697	BC4/GSLC BC4/GSLC BC4/GSLC	U/C2 U/C2 U/C2	MA SS MA	LF LF LF	PIB/S2 PIB/S2 PIB/PS2		Yes Yes
Trulite Glass and Aluminum Solutions 5700 South Moreland Road New Berlin, WI 53155 USA 800-242-2071 IGCC(R)/IGMA(R) Trulite W23 2022	4536 4820 5528	BC4/ALLC BC4/ALLC BC4/GSLC	U/C2 U/C2 U/C2	MA AA PHSS	LF LF LF	PIB/S2 PIB/S2 PIB/S2		Yes Yes Yes
Trulite Glass and Aluminum Solutions 3320-B Maggie Blvd. Orlando, FL 32811 USA 800-367-7211 IGCC(R)/IGMA(R) Trulite W-04 2022	5358	MC4/PK	U/C2	MA	LF	PIB/S2	BA	
Trulite Glass and Aluminum Solutions 1825 S. 43rd Avenue Phoenix, AZ 85009 USA 800-854-8022 Trulite W30 IGCC(R)/IGMA(R) 2022	4120	MC4/PK	U/C2	MA	LF	PIB/S2	BA	
Trulite Glass and Aluminum Solutions 1655 South Awl Circle Salt Lake City, UT 84104 USA 801-656-1660 Trulite W34 IGCC(R)/IGMA(R) 22	3935 5803 5828	MC4/PK/TI MC4/PK MC4/PK	U/C2 U/C2 U/C2	MA MA PHSS	LF LF LF	PIB/S2 PIB/S2 PIB/S2	BA BA BA	Yes Yes
Trulite Glass and Aluminum Solutions 20 Royal Group Cresent Woodbridge, ON L4H 1X9 Canada 905-670-7040 Trulite W90 IGCC(R) IGMA(R) 2022	2032 2295 3806	BC4/GSLC BC4/GSLC BC4/GSLC	U/C1/U U/C2/U U/C2/U	AA/AA SS/SS PHSS/PHSS	LF/LF LF/LF LF/LF	PIB/S2 PIB/S2 PIB/S2		Yes Yes Yes
Trulite Glass and Aluminum Solutions 285 Northbrook Drive Youngsville, NC 27596 USA 919-435-3050 Trulite W20 IGCC®/IGMA® 2022	5301 5341	MC4/PK MC4/PK	U/C2 U/C2	MA PHSS	LF LF	PIB/S2 PIB/S2		Yes Yes

<u>LICENSEE</u>	<u>CERTIFICATION NUMBER</u>	<u>FRAME CONSTRUCTION</u>	<u>SUBSTRATE</u>	<u>SPACER</u>	<u>DESICCANT</u>	<u>SEALANT</u>	<u>INTERNAL COMPONENTS</u>	<u>GCIA</u>
TSY-Fong Glass Co., Ltd 83-1 Jiasing Road Wanluan Township Pintung County Taiwan 923 China 886-8-7835-002	3170	MC4/PK	U/U	AA	LF	PIB/S2		Yes
Tvitec System Glass	5118	MC4/PK	U/C2	AA	LF	PIB/S2		Yes
Parque Empresarial Prado del Espino	5119	MC4/PK	U/C2	AA	LF	PIB/PU2		Yes
C/Impresores 20, despacho 120 Boadilla del Monte, Madrid 28660 Spain +34-915 670 896 ISOLAR Date Batch Line No Cert no IGCC (R)/IGMA(R)	5120	MC4/PK	U/C2	PHSS	LF	PIB/S2		Yes
Unicel Architectural Corp.	3941	MC4/PK	U/C1	PHSS	LF	PIB/S2	BL	Yes
2155 Fernand Lafontaine Longueuil, QC J4G 2J4 Canada 450-670-6844x233 Vision Control IGMA(R)IGCC(R) Month/year	4563	MC4/ALK	U/C1	MA	LF	PIB/S2	BL	Yes
Uniglass 4636 Al Marwa - Al Mishal Unit No. 2 PO. Box 40179 Riyadh 11499 Saudi Arabia +9665471446 UNIGLASS IGCC/IGMA 5033-2022	5033	BC4/ALLC	U/C3	AA	LF	PIB/S2		
Union Glass s.r.l.	5673	BC4/SSLC/AP	U/C2/U	AA/AA	LF/LF	PIB/PS2		Yes
Via Istria	5674	BC4/SSLC/AP	U/C2/U	AA/AA	LF/LF	PIB/S2		Yes
Motta Di Livenza , Treviso 31045	5675	BC4/SSLC/AP	U/C2/U	PHSS/PHSS	LF/LF	PIB/S2		Yes
Italy 0039 34752 62997	5676	BC4/SSLC/AP	U/C2/U	PHSS/PHSS	LF/LF	PIB/PS2		Yes
United Plate Glass Co., Inc.	1513	BC4/GSLC	U/C2	MA	LF	PIB/PU2		
108 Grundman Drive	4699	BC4/GSLC	U/C2	MA	LF	PIB/S2	BA	Yes
Butler, PA 16001 USA 800-772-7783 UPG IGCC(R)IGMA(R) 9/26/2022	5072	BC4/GSLC	U/C2	MA	LF	PIB/PS2	BA	Yes
Unitex Glass Chengdu Co., Ltd 1 Second Section Street Yingbin Jintang County Chengdu, Sichuan 610042 China 86-592-6215300	4436	BC4/GSLC	U/U	AA	LF	PIB/S2		

<u>LICENSEE</u>	<u>CERTIFICATION NUMBER</u>	<u>FRAME CONSTRUCTION</u>	<u>SUBSTRATE</u>	<u>SPACER</u>	<u>DESICCANT</u>	<u>SEALANT</u>	<u>INTERNAL COMPONENTS</u>	<u>GCIA</u>
Val y Val SA de CV Av. Framboyanes Lote 19 Manzana 6 Cd. Industrial Bruno Pagliai Heroica Veracruz, Veracruz 91697 Mexico 52-229-9811036	4948	BC4/SSLC	U/C2	AA	LF	PIB/S2		
Valda 90 Ltd. Dolni Bogrov Sofia 1855 Bulgaria +359 888 955 765 Valda 90 IGCC(R)/IGMA(R) 2022	5182	BC4/SSLC	U/C2/U	PHSS/PHSS	LF/LF	PIB/PU2	BA	
vandaglas Eckelt GmbH ResthofstraBe 18 Steyr A4403 Austria 43 7252 894 0 Eckelt Glas IGCC®/IGMA® 22	2229	BC4/SSLC/AP	U/C2/U	SS/SS	LF/LF	PIB/PS2		Yes
	2230	BC4/SSLC/AP	U/C2/U	SS/SS	LF/LF	PIB/S2		Yes
	5396	BC4/SSLC	U/C3/U	PHSS/PHSS	LF/LF	PIB/S2		Yes
VELUX America LLC 450 Old Brickyard Rd PO Box 5001 Greenwood, SC 29649 USA 864-941-5309 Velux.com IGCC®/IGMA® +date	2035	BC4/PLC	U/C2	SS	LF	PIB/S1		Yes
VETRERIA CAPPELLETTI E ROLERI S.R.L. Via Berlinguer, 67 / 69 Settima di Gossolengo (PC) 29020 Italy	5330	BC4/PLC	U/C2	PHSS/PHSS	LF	PIB/PS2		Yes
	5331	BC4/PLC	U/C2/U	PHSS/PHSS	LF/LF	PIB/S2		Yes
Vetrodomus SpA Via Giovanni Bormioli n°48 Brescia, Province of Brescia 25135 Italy 390303363005 Vetrodomus SpA + date + IGCC(R)IGMA(R)	4491	BC4/SSLC	U/C3	PHSS	LF	PIB/S2		Yes
	4492	BC4/SSLC	U/C3	PHSS	LF	PIB/PS2		Yes
	5087	BC4/SSLC	U/C3	AA	LF	PIB/S2		Yes
View Inc. 12380 Kirk Road Olive Branch, MS 38654 USA 662-892-3415 View, Inc. OB IGCC(R)/IGMA(R) '23	3934	BC3/MC1/MT/SP	U/C2	FSF	IB	PIB/S2		Yes
	5650	BC3/MC1/MT	U/C2	FSF/FSF	IB/IB	PIB/S2		Yes
Viewmax Windows and Doors, Ltd. Huaxin Road 297 Yanggu Liaocheng, Shandong 252323 China +86-18706356127 VIEWMAX IGCC-5259 IGCC®/IGMA® 2023	5259	MC4/PK	U/C2/U	PHSS/PHSS	LF/LF	PIB/S2		Yes

<u>LICENSEE</u>	<u>CERTIFICATION NUMBER</u>	<u>FRAME CONSTRUCTION</u>	<u>SUBSTRATE</u>	<u>SPACER</u>	<u>DESICCANT</u>	<u>SEALANT</u>	<u>INTERNAL COMPONENTS</u>	<u>GCIA</u>
Vinyl Window Designs Ltd. 550 Oakdale Road North York, ON M3N 1W6 Canada 416-741-7820	2521 4519 5025	BC3/MC1/SS BC3/MC1/MT BC3/MC1/MT	U/C2/U U/C2 U/C2	US/US FSF FSF	DM/DM IB IB	RHM PIB/S2 RHM	BA BA BA	Yes Yes Yes
Vinyl Window designs Ltd IGCC(R)/IGMA(R) Date								
Viracon Inc. 800 Park Drive PO Box 990 Owatonna, MN 55060 USA 507-451-9555	1462 1911 4682 980	BC4/GSLC/TI BC4/SSLC/TI BC4 BC4/GSLC/TI	U/C3/U U/C3/U U/C3/U U/C3/U	MA/MA SS/SS RTP/RTP AA/AA	LF/LF LF/LF IB/IB LF/LF	PIB/S2 PIB/S2 RTP/RTP/S2 PIB/S2		Yes Yes Yes Yes
Viracon MN IGCC(R)/IGMA(R) 22								
Vitelsa Mosquera Parque Industrial San Jorge, Av. Troncal de Occidente KM19 Via Mosquera - Madrid, Lote 90 Mz C4 Bod 1 Bogota, Cundinamarca 00 Colombia 3154272038	5630	MC4/PK	U/C1/C2	MA	LF	PIB/S2		
VITROTERM-MUROW S.A. Wolnosci 33 Murow 46-030 Poland 48-601-499-290	4525 5273	BC4/SSLC/AP BC4/SSLC/AP	U/C3/U U/C2/U	PHSS/PHSS PHSS/PHSS	LF/LF LF/LF	PIB/S2 PIB/PS2		Yes Yes
Vitrum Industries Ltd. 9739 - 201st Street Langley, BC V1M 3E7 Canada 604-614-9081	4888 4889 5289 5628	BC4/PLC BC4/PLC BC4/PLC BC4/PLC	U/C2/U U/C2/U U/C2/U U/C2/U	PHSS/PHSS MA/MA AA/AA AA/AA	LF/LF LF/LF LF/LF LF/LF	PIB/S2 PIB/S2 PIB/S2 PIB/PS2	BA BA BA BA	Yes Yes Yes Yes
IGCC@/IGMA@ Vitrum 2022 Langley								
W. A. Wilson Inc. 6 Industrial Park Dr. PO Box 6712 Wheeling, WV 26003 USA 304-232-2200	3854 5253 5465 5669 5670	BC4/GSLC BC4/GSLC BC3/MC1/MT MC4/PK BC3/MC1/MT	U/C3 U/C3 U/C3 U/C2 U/C2	AA PHSS FSF AA FSF	LF LF IB LF IB	PIB/S2 PIB/S2 PIB/S2 PIB/PU2 PIB/PU2		Yes Yes Yes Yes Yes
Starlite IGCC(R)/IGMA(R) 2022	5671	MC4/PK	U	PHSS	LF	PIB/PU2	BA	Yes
W.C.P., Inc dba West Coast Insulated Glass Products 17730 Crusader Avenue Cerritos, CA 90703 USA 562-653-9797	2383 2384 4366 5040 5545	MC4/PK MC4/PK MC4/PK MC4/PK MC4/PK	U/C2 U/C2 U/C2/U U/C2 U	AA AA SS/SS PHF AA	LF LF LF/LF LF LF	PIB/PU2 PU2 PIB/PU2 PIB/PU2 PIB/S2	BA BA BA BA BA	Yes Yes Yes Yes Yes

<u>LICENSEE</u>	<u>CERTIFICATION NUMBER</u>	<u>FRAME CONSTRUCTION</u>	<u>SUBSTRATE</u>	<u>SPACER</u>	<u>DESICCANT</u>	<u>SEALANT</u>	<u>INTERNAL COMPONENTS</u>	<u>GCIA</u>
Westeck Windows Mfg. Inc. 8104 Evans Road Chilliwack, BC V2R 5R8 Canada 604-792-6700 Westeck Windows MFG IGCC(R)/IGMA(R) #4775 + date	5309	BC3/MC1/MT	U/C2	FSF	IB	HM	BA	Yes
Western Reflections, Changshu ZhongXin Building Materials Meili Town Changshu, Jiangsu 215500 China 616-748-5401 XYG IGCC®/IGMA® 2022	39971 41951 41981	MC4/PK BC3/MC1 BC3/MC1	U/C2 U/C2 U/C2	AA BCS BCS	LF IB IB	PIB/PS2 BCS BCS/S2	GI GI GI	
Western Reflections, Vidrio Decorativo Occidental S. A. de C.V. Poniente 4 Entre Borte 7 y Gral Pedro Hinojosa Ciudad Industrial Heroica Matamoros, Tamaulipas Mexico 868-812-9152 VDO IGCC®/IGMA® 2022	30831 33091 40761 41411 48511 52071 52091 56511	MC4/PK MC4/PK/CT BC3/MC1/MT BC3/MC1 BC3/MC1 BC3/MC1 BC3/MC1/MT BC3/MC1	U/C2 U/C2 U/C2 U/C2 U/C2 U/C2 U/C2 U/C2	AA AA FSF BCS BCS BCS UT/UT BCS	LF LF IB IB IB IB DM/DM IB	PIB/PU2 PU2 HM BCS/PU2 BCS BCS RHM BCS	GI BA GI GI GI BA BA BL GI	
Western Reflections, Zeeland 215 E. Roosevelt Avenue Zeeland, MI 49464 USA 616-772-9111 ODL Zeeland IGCC®/IGMA® 2022	30521 43381 55041	BC3/MC1/CT MC4/PK BC3/MC1	U/C2 U/C2 U/C2	UT AA BCS	DM LF IB	RHM PU2 BCS	BA BL BA BA	
White Aluminum Enterprises LLC Plot D14 (51) D11 (48,49) ICAD-1 PO Box 30665 Abu Dhabi United Arab Emirates 97-154-7931702 WAE IGCC/IGMA 2022	2335	BC4/ALLC	U/U	AA	LF	PIB/S2		
Wholesale Glass Dist. 4287 Delp Street Memphis, TN 38118 USA 901-332-2200 WGD 23 IGCC®/IGMA® ASTM E2190	2279 2280	BC4/GSLC BC4/GSLC	U/C2 U/C2	MA MA	LF LF	PIB/S2 PIB/PS2	BA	Yes
WHTB Glass, LLC 101 Precision Dr. Shirley, NY 11967 USA 347-382-9892	5258	BC4/GSLC	U/C2	AA	LF	PIB/S2		

<u>LICENSEE</u>	<u>CERTIFICATION NUMBER</u>	<u>FRAME CONSTRUCTION</u>	<u>SUBSTRATE</u>	<u>SPACER</u>	<u>DESICCANT</u>	<u>SEALANT</u>	<u>INTERNAL COMPONENTS</u>	<u>GCIA</u>
Windsor Windows and Doors 2210 Stafford St. Ext. Monroe, NC 28110 USA 704-283-7459 Windsor NC-1 IGCC(R)/IGMA(R) + date	2349	BC3/MC1/MT	U/C2	FSF	IB	HM	BA	Yes
Windsor Windows and Doors 901 S. Sunset Drive Norwalk, IA 50211 USA Windsor "order number" IGCC®/IGMA® low- e 366 IA-1 mm/yy	5022	BC3/MC1/MT	U/C2	FSF	IB	HM	BA	Yes
Windsor Windows and Doors 900 South 19th Street West Des Moines, IA 50265 USA 515-223-6660 Windsor "order number" IGCC®/IGMA® low- e xxx IA-2 mm/yy	2285	BC3/MC1/MT	U/C2	FSF	IB	HM	BA	Yes
Wujiang CSG Huadong Architectural Glass Co., LTD 869 Pangjin Road Economic Development Zone, Wujiang Suzhou, Jiangsu 215200 China 86-512-81559999	3500	BC4/GSLC	U/C2	AA	LF	PIB/S2		
Xianning CSG Energy Conservation Glass Co., LTD. Guishan Road No. 35 Changjiang Industrial Park Economic Development Zone Xianning, Hubei 437000 China 18827318411	3915	BC4/GSLC	U/C2	AA	LF	PIB/S2		
Xinyi Glass (Jiangsu) Company Limited Xinyi Glass Industrial Park Jianshe Village, Jinfeng Town Zhajiagang, Jiangsu 215625 China (86) 512-5698 9999	5696 5697 5698	BC4/GSLC BC4/GSLC BC4/GSLC	U/C2 U/C2 U/C2	AA MA PHSS	LF LF LF	PIB/S2 PIB/S2 PIB/S2		Yes Yes Yes
Xinyi Glass (Tianjin) Co. Ltd. No. 33 Quanfa Road Wuqing Development Area Wuqing District, Tianjin 301700 China 86-22-59610666 IGCC®/IGMA® E2190 XYG 2022	4167 4168 4169 4933	BC2/MC2/PK/TI BC2/MC2/PK/TI BC2/MC2/PK/TI BC2/MC2/PK	U/C2 U/C2 U/C2 U/C2/U	AA PHSS MA PHSS/PHSS	LF LF LF LF/LF	PIB/S2 PIB/S2 PIB/S2 PIB/S2		Yes Yes Yes Yes

<u>LICENSEE</u>	<u>CERTIFICATION NUMBER</u>	<u>FRAME CONSTRUCTION</u>	<u>SUBSTRATE</u>	<u>SPACER</u>	<u>DESICCANT</u>	<u>SEALANT</u>	<u>INTERNAL COMPONENTS</u>	<u>GCIA</u>
Xinyi Glass (Yingkou) Co., Ltd.	4733	BC4/GSLC	U/C2	AA	LF	PIB/S2		Yes
Xin Yi Industrial Zone	4734	BC4/GSLC	U/C2	PHSS	LF	PIB/S2		Yes
Xin Yi Road	4735	BC4/GSLC	U/C2	MA	LF	PIB/S2		Yes
Yingkou, Liaoning 115007	5232	BC4/GSLC	U/C2/U	PHSS/PHSS	LF/LF	PIB/S2		Yes
China	5236	BC4/GSLC	U/C2/U	MA/MA	LF/LF	PIB/S2		Yes
86-417-8205076	5237	BC4/GSLC	U/C2/U	AA/AA	LF/LF	PIB/S2		Yes
Xinyi Group (Glass) Co., Ltd.	2047	MC4/PK	U/C2	SS	LF	PIB/S2		Yes
Xinyi Glass Industrial Zone	2350	BC4/GSLC	U/C2	MA	LF	PIB/S2		Yes
Humen Town	2352	BC4/GSLC	U/C2	PHSS	LF	PIB/S2		Yes
Dongguan, Guangdong Province 52935	2353	BC4/GSLC	U/C2	AA	LF	PIB/S2		Yes
China								
604-273-0813								
XYG ASTM E2190 IGCC®/IGMA® 2022								
Yakut Cam A.S	5369	BC4/GSLC	U/C2/U	PHSS/PHSS	LF/LF	PIB/S2		Yes
A.gazi mah. Atayolu cad: No. 197	5654	BC4/PK	U/C2	PHSS	LF	PIB/S2		
Sancaktepe, Istanbul 34791								
Turkey								
0216-561-80-81								
YAKUT CAM + IGCC(R)/IGMA(R) 22								
Yantai Dongfang Glass Co., Ltd	5155	BC4/GSLC	U/C2	PHSS	LF	PIB/PS2		Yes
No. 17, Tonghuang Road	5197	BC4/GSLC	U/C2/U	PHSS/PHSS	LF/LF	PIB/PS2		Yes
Zhifu District								
Yantai, Shandong 264004								
China								
+86 135 8594 0662								
Yildiz Cam San. Tic. A.S.	5400	BC4/SSLC	U/C2	PHSS	LF	PIB/S2		Yes
Uzunçiftlik Mah. Rauf Denктаş	5401	BC4/SSLC	U/C2	MA	LF	PIB/S2		
Cad. No: 105								
Kocaeli, Kartepe 41180								
Turkey								
YILDIZ CAM IGCC(R)/IGMA(R) 22								
YinJian DongGuan Glass Engineering Co., Ltd.	4965	BC4/GSLC	U/C2	AA	LF	PIB/S2		
86 Huanbao Road								
Yisha Village, Shatian Town								
Dongguan, Guangdong 523998								
China								
13763279690								
YKK AP America	3870	BC3/MC1	U/C2	BCS	IB	BCS	BA	Yes
4234 Ocmulgee East Blvd	3903	BC4/SS	U/C2	US	DM	RHM	BA	Yes
Macon, GA 31217	4555	BC4/ZS	U/C2	UT	DM	RHM	BA	Yes
USA	4923	BC3/MC1	U/C2	BCS	IB	BCS	BA	Yes
YKK AP America INC IGCC(R)/IGMA(R)								
IGCC# Date								

<u>LICENSEE</u>	<u>CERTIFICATION NUMBER</u>	<u>FRAME CONSTRUCTION</u>	<u>SUBSTRATE</u>	<u>SPACER</u>	<u>DESICCANT</u>	<u>SEALANT</u>	<u>INTERNAL COMPONENTS</u>	<u>GCIA</u>
Zhaoqing CSG Energy Conservation Glass Co., Ltd No.8 Baolong Road Zhaoqing High-tech Industrial Development Zone Zhaoqing, Guangdong Province 526238 China +8615813898213	5631	BC4/GSLC	U/C2	AA	LF	PIB/S2		Yes
Zhongli Glass Co., Ltd No. 8 Beihu Road Tianzihu Modern Industrial Park, Anji Huzhou, Zhejiang 313309 China 0752-5898366	3067	BC4/GSLC	U/C2	AA	LF	PIB/S2		Yes
	4362	BC4/GSLC	U/C2	PHSS	LF	PIB/S2		Yes

"IGCC®/IGMA® PROTOTYPES IN PROGRESS"

The following candidate Licensees have a prototype test in progress for possible inclusion in the Program.

MANUFACTURERS

A3 Glass Fabricator LLC	Houston, TX
Accurate Engineering (Pvt) Ltd	Uswetakeiyawa, Sri Lanka
AGC Europe	Teplice, Czech Republic
AGNORA LTD	Collingwood, Ontario
Al Kuhaimi Metal Industries- Stainless Steel and Glass Division	Dammam, EST Province
AL-Hadi Glass Industries	Safat, Kuwait
Aluminum Manufacturers Co. Ltd - ALUMATEC	Jeddah, Saudi Arabia
Aluminum Technology Auxiliary Industries	Doha, Qatar
American Insulated Glass LLC.	Conley, GA
ARAS CAM INS. SAN. VE TIC. A.S.	IZMIR, GAZIEMIR
Beijing Haiyangshunda Northtech Glass Ltd.	Daxing District, Beijing
Blue Star Glass Inc.	Dallas, TX
Blue Star Glass Inc.	North Brunswick, NJ
Central Valley Glass & Screen, Inc.	Sacramento, CA
ChangShu Maybo Glass Co., Ltd.	Changshu, Jiangsu
Clad Tech International LLC.	Ras Al Khaimah, United Arab Emirates
ClearVue Technologies Ltd.	Shanghai, China
Complete Line Glass Wholesalers, Inc.	San Antonio, TX
Cristacurva	Zapopan, Jalisco
Dallas Flat Glass Distributors, Inc.	Carrollton, TX
Dost Cam A.S.	Izmir, Turkey
Downey Glass	Pompano Beach, FL
GLASPRO	Santa Fe Springs, CA
Glassline Industries	ShouEIFat, Mount Lebanon
Glasswerks LA, Inc.	South Gate CA
Glasswerks LA, Inc.	South Gate, CA
Hartung Glass Industries	Tukwila, WA
ITI Glass Company	Bel Aire, KS
Jiangmen Junfa Safety Glass Co., Ltd.	Jiangmen, Guangdong Province
Jiangsu Kemeili Energy Conservation Technology Co., LTD	Suzhou, Jiangsu
Krystalla Vasiliou LTD (VasGlass)	Vasiliko Chalkida, Greece
La Tecnica Nel Vetro SpA	Scafati, Salerno
Laurier Architectural, Inc.	Laurier-Station, Quebec
M Industria S.A. DE C.V.	Conkal, Yucatan
Naverra	Norwich, CT
New Al Khalidiya Aluminium and Glass Co LLC	Abu Dhabi, United Arab Emirates
Northwestern Industries, Inc- Yuma, AZ	Yuma, AZ
Novavetro S.r.l.	San Severino Marche, Province of Macerata

ODL, Inc.	Zeeland, MI
PA Glass Inc.	Philadelphia, PA
PRL Glass Systems	City of Industry, CA
ProTemp Glass, Inc.	Concord, Ontario
Qinhuangdao Xinhua Glass Processing Ind. Co. Ltd.	Qinhuangdao, Hebei
Resman Glass PVC Aluminum SAN. VE TIC. A.S.	Samsun, Tekkekoy
Safti First	Merced, CA
ShanDong HaanGlas Co., LTD	Tai'an, Shandong
Shandong Taishan Huayue Glass Co., Ltd.	Tai'an, Shandong
Shandong Wensheng Glass Technology Co., Ltd.	Jinan City, Shandong, China
Sierra Pacific Windows	Merrill, WI
SIGCO, Inc.	Westbrook, ME
TG Tianjin Glass Co., LTD	Jinghai, Tianjin
Thermafix A.J. Inc.	Amos, Quebec
Thermafix A.J. Inc.	Baie St. Paul, Quebec
Thermafix A.J. Inc.	St. Nazaire, Quebec
Tianjin Northglass Industrial Technical Co., Ltd.	Baodi District, Tianjin
TOTAL MONT LLC- (DBA WESTERN STATES GLASS)	Long Beach, CA
Tower Insulating Glass LLC.	Bellmore, NY
Tristar Glass, Inc.	Catoosa, OK
Turancam Ins. San. Ve Tic A.S.	Cekmekoy, Istanbul
United Plate Glass Co., Inc.	Lincolnton, NC
Vetriko S.A.	Duran, Guayas
Vision En Cristal Y Aluminio SA DE CV	Nuevo Leon, Mexico
Vista Glass Corporation	Vaughan, Ontario
Westeck Windows Mfg. Inc.	Chilliwack, British Columbia
Whalley Glass Co	Derby, CT
WHTB Glass, LLC	Shirley, NY
Wujiang CSG Huadong Architectural Glass Co., LTD	Suzhou, Jiangsu
Wujiang Golden Glass Technologies, Ltd.	Suzhou, Jiangsu
XYG North America Corp.	Wuqing District, Tianjin
Yildiz Cam San. Tic. A.S.	Kartepe, Kocaeli
YKK AP America	Macon, GA

NOTICE: In accordance with the terms of the Procedural Guide, the IGCC® Standard License Agreement, a manufacturer with a prototype product test in progress is not authorized to use the permanent Certification label for that product or to certify that its product is in compliance with Program Standards and Procedures until a passing prototype test report for that product is presented by the manufacturer to the Certification office and the manufacturer is otherwise in compliance with IGCC®/IGMA® Program Procedures.



Administrative Management Systems, Inc.
Administrative Office
PO Box 730, 205 West Main
Sackets Harbor, NY 13685
Phone: (315) 646-2234
E-mail: igcc@amscert.com



PROCEDURAL GUIDE

(IGCC® Document ID-07)

INSULATING GLASS CERTIFICATION COUNCIL AND INSULATING GLASS MANUFACTURERS ALLIANCE IGCC®/IGMA® CERTIFICATION PROGRAM FOR SEALED INSULATING GLASS

1.0 FOREWORD

Acceptance of certified sealed insulating glass comes with the conviction that such certification assures a high level of quality and the integrity of the identifying mark or certification label is being reliably maintained by a competent certifying agency.

The existing ASTM specification(s) for sealed insulating glass provides a sound technical basis for the required quality of sealed insulating glass. With the addition of independent administration plus periodic routine in-plant visits and product evaluation, a program of product certification is developed in accordance with accepted standards. The certification program described here is predicated upon the concept of independent and impartial administration of the certification procedures in the IGCC® license agreement.

To ensure administration of the certification program in a uniform and equitable manner, this procedural guide has been prepared for the information and guidance of the licensees.

It should be noted that the "IGCC® License Agreement" is the governing document for operation of the certification program. This procedural guide, which is not an extension of that document, serves merely to describe the administrative procedures and routine operation of the certification program.

The standards utilized in the IGCC®/IGMA® program for authorizing certification to is the **ASTM E2190-19** (Modified 2/2003)

2.0 GENERAL INFORMATION

The Certification Concept

The IGCC®/IGMA® Certification Program is based upon the conviction that no standard of quality is good without the continuous adherence of the licensees to that standard. To buyers, specifiers, code officials and users, the IGCC®/IGMA® certification label offers the

manufacturers assurance that his sealed insulating glass units have been produced in conformance to the ASTM specification(s).

Who Can Participate?

Every manufacturer of sealed insulating glass is eligible, on a voluntary basis, to participate.

Who Conducts the Program?

The Insulating Glass Certification Council (IGCC®) and the Insulating Glass Manufacturers Alliance (IGMA®), are the sponsors of this certification program. Under License with IGMA®, IGCC® administers and Governs the certification program under which the Administrator periodically checks and reports compliance of the manufacturers of products having the IGCC®/IGMA® certification label.

Administration

Administrative Management Systems, Inc. (AMS) is the independent administrator of the certification program. AMS maintains the IGCC®/IGMA® office of certification and handles the routine day-to-day business. All transactions are done in the name of IGCC®/IGMA®.

How Can You Become a Licensee?

The following steps must be accomplished before IGCC®/IGMA® can authorize a manufacturer to use the IGCC®/IGMA® permanent label: (Modified 8/2009)

- a) The manufacturer must present a passing prototype report from an approved IGCC®/IGMA® testing laboratory to the office of certification (**see also IGCC Certification Note CN IG1010 – Provisional Certification**). Fabrication of prototype test samples shall be witnessed by a representative of the Administrator during a plant audit, at which time the manufacturers compliance with IGCC®/IGMA® Quality Assurance requirements is validated. (See *Section 10.0*) (Modified 9/16/2022)
- b) The manufacturer signs a copy of the IGCC® License Agreement and sends it to the office of certification. IGCC® will countersign this copy and email it to the licensee.
- c) The licensee sends the office of certification the necessary certification fee.
- d) After receipt by the office of certification of the above, the administrator validates that particular model and sends to the licensee a "Notice of Authorization to Use the IGCC®/IGMA® Permanent Label." The permanent label must be affixed on each certified sealed insulating glass unit.
- e) The certified model will then be listed in the next published Certified Products Directory and on the IGCC® website at www.igcc.org.

3.0 HOW THE CERTIFICATION PROGRAM WORKS

American Society for Testing and Materials (ASTM) has test methods and specifications for sealed insulating glass. Sealed insulating glass must meet or exceed the applicable specification before it can be certified.

Recognized independent testing laboratories conduct all tests. The certification committee shall approve all laboratories, whose test reports are utilized by this certification program.

As the sole judge of compliance with the applicable specifications, the administrator authorizes a product, which has been approved to be listed in the Certified Products Directory.

Licensees label sealed insulating glass units in accordance with the labeling requirements established by the Certification Committee.

Approved products are listed in the Certified Products Directory, which is published every six months. It is sent to door, sash and building manufacturers, glazing contractors, homebuilders, architects, regulatory agencies and code-making groups, etc. Directory listings contain the licensee's name, plant location and product description.

The administrator verifies the production at the licensee's manufacturing location during twice per year audits. Audits are performed by a representative of the administrator. At the discretion of the Administrator, one audit each year may be performed virtually (more frequent virtual audits may be deemed necessary in consideration of external factors, i.e. public health conditions). During each of these audits, the manufacturer's compliance with IGCC®/IGMA® Quality Assurance requirements is validated (See *Section 10.0*). The prototype test report must be submitted within one year of the report date in order for the report to be considered as the test for the first year, two audits will take place at which time the auditor will compare current production with the product authorized to use the IGCC®/IGMA® permanent label.

During the first audit in the second year, specimens will be fabricated for testing. IGCC®/IGMA® will ask the manufacturer to produce a minimum of thirteen test specimens. The fabrication of these test specimens is witnessed and verifies that they are produced in accordance with the construction certified. During test specimen fabrication, only the IGCC®/IGMA® auditor and employees of the licensee being audited shall be present. The licensee is instructed to send these test specimens to an approved IGCC®/IGMA® testing laboratory where they are tested. The specimens must be shipped to the laboratory within four weeks of fabrication. Tests are made at the laboratory recommended by the licensee and selected by the administrator from the approved list.

A monthly report listing the status of testing is provided to the licensee by the office of certification on the 15th of each month. Upon completion of the test, the administrator e-mails results promptly to the licensee.

After initial certification (Prototype) testing, ASTM E2190 testing shall occur annually for the first 2 years of certification. If no failures occur, then testing may occur once every 2 years, at the discretion of the participant. Except for prototypes, upon fabrication, test specimens, and

related information and reports, become the property of the certification program (IGCC). (Modified 5/3/2017)

4.0 COMPLIANCE SAFEGUARDS

How is Compliance Assured?

Any certified product found in the course of routine audit and evaluation not to be in compliance with the model description or quality assurance requirements is subject to having authorization to use the IGCC®/IGMA® permanent label removed. The licensee is sent a request for clarification giving 30 days in which to demonstrate to the satisfaction of the administrator that the product is in compliance with the model description that is certified. If the licensee does not respond, a warning of possible removal of authorization to use the IGCC®/IGMA® permanent label is sent giving an additional 30 days to respond. If the licensee does not respond, authorization to use the IGCC®/IGMA® permanent label is **automatically terminated** at the end of that 30-day period.

In the case of a routine test failing to comply with the specifications, the licensee will be officially notified that within 15 days they must respond by stating that a retest fabrication is requested and by paying all administrative and test fees. If there is no response within the 15 days, authorization to use the IGCC®/IGMA® permanent label is **automatically terminated**. If the retest option is accepted, the administrator will perform an audit and witness fabrication of the retest specimens within 45 days. (See *Section 13.6* guideline G.16)

Challenging a Certified Product

Complaints of non-compliance from any corporation or business source will be investigated promptly upon receipt of the complaint in writing along with an appropriate surety deposit. A minimum surety deposit of \$1,500 will be required for each complaint of non-compliance. The surety deposit will be assessed at the rate of \$300 per man-day plus the reasonable cost of travel and other expenses entailed in resolving such incidents. Refunds of part or all of the surety deposit will be made when applicable. The surety deposit will cover all costs involved, unless the investigation proved non-compliance, in which case all costs will be borne by the licensee found to be in non-compliance.

Complaints by Consumers

The administrator shall receive and log the complaint. It will be the consumer's responsibility to identify the label, information appearing on the spacer of glass and advise the administrator of the same. Note: If no IGCC®/IGMA® label exists, the product has not been certified by the manufacturer to IGCC®/IGMA® and the administrator and IGCC®/IGMA® have no further responsibilities or options.

Once the consumer has identified the label, name, etc. they should advise the administrator. The administrator shall respond, advising the consumer of the name, address, primary contact, model description and other pertinent information at hand as it pertains to the subject licensee. Note: If the complaint is being made for reasons of product appearance or failure such as glass quality, fogging, seal failure, dust, etc., the consumer shall be advised to contact the licensee for manufacturer directly. Some manufacturers and their dealers or distributors offer

warranties on their products. Normal claims, procedures and legal remedies are available to consumers on a state-by-state basis.

If the consumer wishes to determine whether or not a labeled product is in compliance with the model described through an investigation by IGCC®/IGMA®, the corporation or business challenge procedure shall be utilized. The surety deposit shall be modified to \$400 and charges per man-day and shall be assessed against the surety deposit in the amount of \$300 plus reasonable travel costs and other expenses.

Withdrawal of Certified Product

Any product which has been authorized to use the IGCC®/IGMA® permanent label may be voluntarily withdrawn from the Certification Program by the licensee at any time. (Modified 8/2009)

5.0 COSTS

What Does the Program Cost?

The initial administration fee will be based on the date of authorization to use the IGCC®/IGMA® permanent label in a manner that participation in the Certification Program will be on a February 1 to January 31 basis thereafter. If the authorization date is between August 1 and December 1, 50% of the administration fee for the first year will be charged for participation and will include one audit prior to the following February 1 date. A licensee is invoiced for each item that is certified and listed separately in the Certified Products Directory. An additional invoice for testing laboratory fees will be issued upon fabrication of test units. For current fee schedule, contact the Administrative office or visit www.igcc.org.

Testing of these units will not begin until payment has been received. Should failure of these units occur during certification testing, any remaining balance will be refunded to the licensee upon request. (Modified 8/2009)

6.0 DOCUMENTS AND AGREEMENTS

License Agreement

This agreement, incorporating independent program administration and routine, periodic, independent plant audits, sampling and evaluation, governs the relationship between IGCC® and the licensee.

Future amendments or revisions to the License Agreement will be recommended by the Certification Committee and enacted by the IGCC® Board of Governors.

Effective Date, Duration, and Termination

The License Agreement becomes effective on the date of its execution, has an initial duration of twelve months (adjustable to a February 1 to January 31 basis), and is automatically renewed for successive twelve-month periods, unless either party gives notice, at least sixty days prior

to date of expiration, that cancellation is requested or unless revoked by IGCC® for causes set forth in the document.

Administrative Service Agreement

This agreement entered into by IGCC® and Administrative Management Systems, Inc. (AMS) governs the relationship between IGCC® and AMS, the independent administrator. In general, it provides that the administrator:

- a) Routinely audits licensee manufacturing facilities twice per year, and during the first audit in the second and subsequent years, witnesses fabrication of specimens for testing at one of the IGCC®/IGMA® approved testing laboratories;
- b) Has the right to witness any and all testing;
- c) Reviews all test reports in order to determine compliance of the certified product with the specifications;
- d) Audits and recommends for approval, all test laboratory facilities for use in this certification program Test laboratories are recognized or approved by the Certification Committee;
- e) Publishes and mails/emails the IGCC®/IGMA® Certified Products Directory twice each year and handles all routine clerical duties of IGCC®/IGMA® with respect to certification matters;
- f) Acts as IGCC® treasurer, invoicing licensees, maintaining a bank account and dispersing funds (fiscal reports are made to the Board of Governors);
- g) Attends all scheduled meetings of the Certification Committee; and
- h) In all of its actions acts in the name of IGCC®.

IGCC®/IGMA® Administration Services and Exclusive Licensing Agreement

This agreement defines the relationship where IGMA® and IGCC® desire to combine the administration and marketing of their two certification programs into one certification program administered and governed by IGCC® under which both the IGCC® Mark and the IGMA® Mark are licensed to certification program participants meeting the requirements ("IGCC®/IGMA® Certification Program")

Procedural Guide

This guide outlines program procedures in accordance with the provisions of the License Agreement and the Administrative Service Agreement, for the guidance of those concerned with the procedural details of the Certification Program's operation. It covers the steps to be taken in any given procedural situation in the interest of equitable and uniform treatment of licensees and the preservation of the integrity of the certification program.

Certified Products Directory

This directory is the one document and publication that is normally in the public's eye and contains a listing of the certified seal insulating glass units of each licensee.

Certification Label

The licensee permanently affixes this certification mark to each unit of certified sealed insulating glass. This certification mark may be reference to the Licensee's listing in the Certified Products Directory. The listing then provides a product description including the company name, plant location, etc. (Modified 8/2009)

7.0 PROGRAM RESPONSIBILITY

IGCC® Board of Governors

The IGCC® Board of Governors overall responsibility is for the well-being and acceptance of the Certification Program by the industry, building officials and the public. It also bears legal corporate responsibility.

IGMA® Board of Directors

The IGMA® Board of Directors may make recommendations to the IGCC® Board regarding the IGCC®/IGMA® Certification Program and may appeal any decision of IGCC® regarding certification or the IGCC®/IGMA® Certification Program.

IGCC® Certification Committee

The IGCC® Certification Committee has the responsibility for the general procedure and policy pertaining to operation of the Certification Program. As a part thereof, it: (Modified 8/2009)

- a) establishes "guidelines",
- b) determines the applicability of the specifications in a specific situation where a question is raised by a licensee or the administrator,
- c) approves test laboratories,
- d) determines which of the specifications are to be designated effective for the purposes of product certification and the date or dates on which they become effective, and
- e) recommends to the IGCC® Board of Governors changes to be made in the License Agreement.

8.0 LABEL REQUIREMENTS

THE IGCC®/IGMA® CERTIFICATION LABEL MUST BE PERMANENTLY MARKED ON A VISIBLE PORTION OF EACH SEALED INSULATING GLASS UNIT OR IT IS NOT CERTIFIED BY THE MANUFACTURER TO THE PUBLIC. The label shall be etched, sand blasted, embossed, printed, painted or otherwise permanently marked on the spacer or at least one component pane of the sealed unit. (See Note #1 & #2 below)

This label must be visible after installation in the building. The IGCC®/IGMA® permanent label must be in block capital letters and have a minimum height of 0.050 inches (1.27 mm).

The letters IGCC®/IGMA® must be followed by the ® registration mark or a close facsimile, i.e., IGCC®/IGMA®. The IGCC®/IGMA® permanent label must contain the company identification (company name, trade name or company code), plant code*, registered "IGCC®/IGMA®" mark and a date code spanning no more than a 12-month period, plus or minus three months. The date code should commence with the beginning of each calendar year (effective for both the beginning and the ending of each period). Outdated spacers may be hand stamped to bring the label up to date. The plant code will only be required when there is more than one plant with an IGCC®/IGMA® certified product operating under the same company name. The IGCC®/IGMA® permanent label must be affixed to certified products only at the time and place of manufacture. The labeling must be approved by the administrator. The permanent label must be affixed only to the sealed insulating glass units of the licensee's own manufacture which have been certified by the manufacturer through IGCC®/IGMA®.

The permanent label must not be sold, transferred or otherwise disposed of in any manner other than being affixed to the licensee's certified production. The permanent label must not be affixed to any product from which certification has been withdrawn or which is produced with a process basically different from the one used when certification was obtained.

Example of Minimum Label:

ABC Glass Co.(*) IGCC®/IGMA® '21

The IGCC®/IGMA® permanent label is listed under each company's name in the "Certified Products" section of this directory.

* A plant code will only be required when there is more than one plant with an IGCC®/IGMA® certified product operating under the same company name.

Note#1:

When an NFRC certified window, door, skylight fabricator also fabricates IGCC®/IGMA® certified IG units and glazes these IG units into their own NFRC certified product, the IGCC®/IGMA® permanent label may appear on the window, door, skylight NFRC permanent label in lieu of the IGCC®/IGMA® permanent label appearing on the actual IG unit. IGCC®/IGMA® required label content and NFRC permanent label requirements shall apply. (Modified 8/2010)

For Example:

NFRC 123 - N - 456 ----- ABC Windows - Dallas IGCC®/IGMA® 2021
--

Note#2:

When a certification listing bares a "PC" designation, this means the product has been certified by the Provisional Certification process (see also IGCC Certification Note CN IG1010 – Provisional

Certification). Actual product does not need to be labelled with the PC designation, but all other label requirements shall apply.

9.0 ADVERTISING GUIDELINES

The following concepts are important to remember whether you are a participant, licensee in the IGCC®/IGMA® Certification Program, or a supplier to the sealed insulating glass industry. This discussion is intended to provide you with an accurate background description of the IGCC®/IGMA® Certification Program, to help you avoid making possibly misleading, deceptive, or ambiguous statements regarding the program in the advertising of your products. (Modified 8/2009)

- 1) IGCC®/IGMA® is the sponsor of a certification program. IGCC®/IGMA® does not certify products.
- 2) The administrator audits laboratories and checks their equipment, audits licensees' production and fabrication of specimens, and validates test reports and certification claims.
- 3) Laboratories test specimens to specific test methods and specifications referenced by IGCC®/IGMA®
- 4) Manufacturers/licensees "certify" their products, affirming that their products are constructed similarly to specimens which were audited, tested and found to pass the stated criteria. A Licensee's Certification Statement is the imprinting, sandblasting, etching or other form of permanent marking of an IGCC®/IGMA® certification program designation and number to its product.
- 5) The IGCC®/IGMA® Certification Program does not have "members," inasmuch as the term "members" carries with it a connotation that some detailed criteria must be met in order to participate in the organization. Under the IGCC®/IGMA® concept, anyone can participate, and "participants" simply must possess a "legitimate interest in the purposes of IGCC®/IGMA®." Manufacturers, on the other hand, which are "fabricators of sealed insulating glass units," become participants by virtue of executing a License Agreement with IGCC®. Any manufacturer of insulating glass may voluntarily enter into a License Agreement, provided that they intend to certify at least one product under the IGCC®/IGMA® Certification Program. Thus, the proper term to use for a manufacturer participant is "Licensee." A manufacturer, with a prototype in progress, is termed a "Candidate Licensee."
- 6) Unit specimens, not their components, are tested under the IGCC®/IGMA® program. Thus, if you are a supplier to the industry, statements indicating that your components have complied with the test methods would be incorrect. A better nomenclature for example, would be, that "Units tested to ASTM E2190 contained our X component have been found to meet the requirements of the specification(s)."

- 7) Should you have any questions concerning the IGCC®/IGMA® Certification Program, please contact:
- Insulating Glass Certification Council
Mr. John G. Kent
PO Box 730, 205 West Main Street
Sackets Harbor, NY 13685
Telephone: (315) 646-2234
E-mail: igcc@amscert.com

8) **ANSI Disclaimer

Although the IGCC Program is ANSI-accredited and uses the ANSI accreditation symbol on its publicity material the IGCC-certified Licensee cannot use the ANSI trademark nor the ANSI accreditation symbol, this includes its products, packaging, stationary, letterhead, or any other form of media.

10.0 QUALITY ASSURANCE PROGRAM

IGCC®/IGMA® require licensees to have a working quality assurance program for the fabrication of insulating glass. As a minimum, the licensee's quality assurance system must comply with the general requirements of IGMA TM-4000-02(07) "Insulating Glass Manufacturing Quality Procedures Manual" which established 1) general requirements for quality systems and 2) provides practical solutions for implementing such a system. IGCC®/IGMA® requires compliance to these general requirements of IGMA TM-4000-02(07) "Insulating Glass Manufacturing Quality Procedures Manual" but does not define the specifics of the quality assurance system which should be appropriate for the type, range and volume of work performed.

Adherence is verified during twice per year plant visits. These requirements were adopted to improve the overall quality of IG units in the program, and also to satisfy requirements established by the Department of Housing and Urban Development, HUD, the National Fenestration Rating Council (NFRC) and other regulatory and consumer driven organizations.

A licensee's QA program shall comply with IGMA TM-4000-02(07) "Insulating Glass Manufacturing Quality Procedures Manual" which establishes requirements for the following: (Modified 02/03/2015)

- 1) A quality systems manual
- 2) A designated person responsible for quality assurance
- 3) Process Control
- 4) Inspection and Testing (Spacer, Desiccant, Sealant, Gas Fill, Finished Product, Glass)
- 5) Calibration
- 6) Non-Conforming Products and Corrective Action
- 7) Storage and Handling

- 8) Field Service
- 9) Internal Quality Audits
- 10) Training
- 11) Statistical Techniques

11.0 GAS CONTENT INITIAL AND AFTER WEATHERING CERTIFICATION AND TESTING (GCIA)

A licensee must certify to seal durability requirements to participate in the gas content program. The IGCC®/IGMA® Gas Content program is voluntary if gas content units will NOT use IGCC®/IGMA® marked spacer, but is mandatory if IGCC®/IGMA® marked spacer will be used for gas content units. The program is intended to demonstrate a licensee's ability to initially fill to a minimum level and the ability of the construction of the IG unit to retain a minimum gas content level after exposure to the ASTM E2190 weathering cycle.

Licensees meeting a tested initial gas content of 90% or greater and a final after weathering gas content of 80% or greater shall be identified in the Certified Products Directory (CPD) with the designation "GCIA" for "Gas Content, Initial and After Weathering". Both initial and after weathering gas content must be compliant in order to be listed as "GCIA". The gas content certification process will be as follows: (Modified 8/2010)

- 1) The normal minimum of thirteen (13) 14x20-inch (355x505 mm) test units for seal durability, fifteen (15) for multiple air space units, shall be fabricated under auditor witness during normal durability certification fabrication audits. All test units shall be gas filled with argon. All multiple air space units shall have both cavities filled and tested. Per guideline G.19 as applicable, coated glass shall be used and multiple air space units shall have coated glass as the center lite for at least ten (10) test units intended for testing in accordance with ASTM E2188 and have coated glass on at least one outer lite for at least four (4) test units intended for testing in accordance with ASTM E2189. The test lab shall randomly select ten (10) units for initial gas content testing except that units containing internal components (IC) (i.e. grills or muntins) shall not be considered for testing. Units shall be inspected for any damage, and any damaged units not used. Testing for gas content after weathering shall be performed on the six (6) ASTM E2190 weathering test units.
- 2) Production Units - As of 6/23/2010 selection and testing of production units is not required.
- 3) Units shall be tested for initial and after weathering gas content percent by non-destructive spark emission spectroscopy (SES) in accordance with ASTM E2649 Determining Argon Concentration in Sealed Insulating Glass Units Using Spark Emission Spectroscopy. Up to two (2) test units (14x20") may be used to replace any unit broken in shipping or handling.
- 4) Laboratories shall report results of testing as "percent initial gas content" and "percent after weathering gas content" to the nearest whole percent.

- 5) The calculation of percent initial gas content shall be the average of all ten (10) units tested. The calculation of percent after weathering gas content shall be the average of all six (6) weathered test units.
- 6) To be listed as complying with gas content certification, initial and after weathering (GCIA) the average gas content level must be 90% or greater initially and 80% or greater after weathering, and each of the tested units shall have a gas concentration of 50% or greater. These levels were selected as levels that can reasonably be reached by insulating glass fabricators on a consistent basis. It takes into consideration a) variations that may occur in the filling process, and b) variations that may occur in the testing process. If a licensee feels that its gas content is consistently greater than these gas content values, the licensee can include this information in the licensee’s literature.
- 7) It is recognized that actual production units may not necessarily be 90% or greater initial gas content but shall meet the manufacturer’s stated initial content values.
- 8) Special arrangements need to be made if regulatory compliance is required for gas content other than argon.

12.0 COMPONENT VALIDATION

Sealant Fingerprinting - To help understand variability in an IG total unit performance, an optional tool, sealant “Fingerprinting” can provide fabricators with an avenue to better understand test results and material variability. The output of a sealant fingerprint is a graphical representation of the generic make-up of a material that then can be compared to other fingerprints of the fabricator to better understand the material. Fabricators can create their own “vault” for their company’s “pre” and/or “post” ASTM weathering testing. The information (Fingerprint) shall be the property of the company requesting the test. Contact IGCC at staff@amscert.com for more information or visit the IGCC®/IGMA® website (www.igcc.org). (Adopted 7/12/2018)

13.0 CERTIFICATION GUIDELINES AND INTERPRETATIONS

For guidance in labeling and certifying sealed insulating glass units the Certification Committee has adopted the below guidelines.

Additionally, certain topics that required added explanation and clarification have been presented in a series of Certification Notes as referenced. These Certification Notes are available on the IGCC®/IGMA® website (www.igcc.org) or by contacting the administrative office.

ID #	Title	Initial Publish Date	Approval Date
CN IG 1009	Certification of Internal Components (IC)	10/28/09	7/24/2019

CN IG 1109	Certification of Capillary Tube, Breather Tube Systems (Deleted 5/4/22)	10/28/09	10/28/09
CN IG 0310	Certification of Multiple Air Space Units	3/1/10	5/7/14
CN IG 1010	Provisional Certification	10/14/10	9/16/22
CN IG 0211	Certification and Testing of Vacuum Insulating Glass VIG	2/18/11	9/26/22
CN IG 0112	Desiccant Quantity Review of Changes (ACPF)	1/31/12	10/31/12

ALWAYS

13.1 The following situations permit the licensee to **always** certify the sealed insulating glass units with the same IGCC®/IGMA® number.

13.1.1 GLASS

A.GL.1

Any change in glass thickness from that tested. (Modified 3/15/2006)

A.GL.2

Any change in glass tint or color from that tested (clear glass is required in test specimens).

A.GL.3

Any change in glass size from that tested (14x20 inches is required for test specimens).

A.GL.4

Any change in glass type (i.e. tempered, heat strengthened, laminated or patterned glass) from that tested (annealed glass is normally used in all test specimens).

A.GL.5

Any change in glass shape from that tested (rectangular glass is required in test specimens). This guideline permits the same IGCC®/IGMA® number for triangular, circle head, trapezoidal and other shapes.

A.GL.6

Any change in glass supplier from that tested.

A.GL.7 (Deleted 3/15/2006)

A.GL.8 (Deleted 3/15/2006)

A.GL.9 (Deleted 3/2/2011)

13.1.2 SPACER

A.SP.1

Any change in air space dimension from that tested (one-quarter inch to one-half inch air space is allowed for testing).

A.SP.2

Any change in spacer wall thickness from that tested.

A.SP.3

Any change in spacer seam design (i.e. butt seam or lock seam) from that tested.

A.SP.4

Any change in supplier of spacer from that tested, everything remaining the same.

A.SP.5

Corners or connections which are soldered, welded, brazed or bent, but uncut, may be used interchangeably with the same IGCC®/IGMA® number. (Adopted 2/19/1985)

A.SP.6

Corners or connections may be changed from mechanical connections (MC) to bent-uncut corners (BC), using the same IGCC®/IGMA® number utilizing joiners or corner keys of plastic, aluminum, stainless, or galvanized steel. (Modified 5/14/2008)

A.SP.7

Any change in spacer profile from that tested. (Adopted 7/29/2004)

13.1.3 INTEGRATED SPACER SYSTEMS

Defined as a pre-fabricated multi-component, multi-material and/or multi-function spacer system. Contact the IGCC®/IGMA® Administrative Office for the most current list of reviewed integrated spacer systems and their generic class.

A.SS.1

A licensee may certify a Plastic Hybrid Integrated Spacer System (ISS) on the "IGCC®/IGMA® List of Reviewed Integrated Spacer Systems" utilizing the same IGCC®/IGMA® number as the basespacer generic material (single homogeneous component) provided regular test units include the plastic hybrid ISS, all other guidelines applicable. (Adopted 1/31/2012)

A.SS.2

A licensee may use a temporary alternate integrated spacer system on the IGCC®/IGMA® list of reviewed integrated spacer systems (most current version) in the same generic class by:

- a. notifying the administrator of the change,
- b. having test specimens witnessed by the administrator's representative at the next regular audit, and
- c. sending the test specimens to an IGCC®/IGMA® approved testing laboratory within four (4) weeks of the test specimens' fabrication date.

However, Guideline G.26 shall apply where applicable. The licensee may temporarily use the certification label on a provisional basis commencing with written notification from the administrator and ending when test results are received by the administrator. (Modified 1/31/2012)

13.1.4 DESICCANT

A.DE.1

A manufacturer may use the same IGCC®/IGMA® number on production units having air space thickness equal to, or greater than the model tested provided the desiccant Adsorption Capacity per Perimeter Foot (ACPF) remains the same (-10%) or is greater. A manufacturer may use the same IGCC®/IGMA® number on production units having an air space thickness smaller than the model tested provided the manufacturer maintains the same or more sides filled with desiccant (Modified 1/31/2012)

A.DE.2

A change in supplier or model of the same generic type of desiccant from that tested will not require a different IGCC®/IGMA® number provided the new material is on the list of IGCC®/IGMA® reviewed desiccants and the ACPF is maintained or increased. However, Guideline A.SS.2 shall apply where applicable. (Modified 10/28/2015)

A.DE.3

The use of the same loose fill desiccant manufactured in different particle size ranges will not require a different IGCC®/IGMA® number. (Modified 1/31/2012)

A.DE.4 (Deleted 1/31/2012)

A.DE.5 (Deleted 1/31/2012)

A.DE.6 (Deleted 1/31/2012)

13.1.5 SEALANT

A.SE.1

If a fabricator produces IGUs with the same sealant/spacer system, but with different sightline dimensions (i.e. with a narrow and standard sightline dimension), they must certify the system with the smallest sealant/spacer sightline dimension. Verification of smallest sightline shall be confirmed during IGCC®/IGMA® fabrication audits. (Revised 9/26/2018).

A.SE.2

A licensee may use a temporary alternate sealant on the IGCC®/IGMA® list of reviewed sealants (most current version) in the same generic class by:

- a. notifying the administrator of the change,
- b. having test specimens witnessed by the administrator's representative at the next regular audit, and
- c. sending the test specimens to an IGCC®/IGMA® approved testing laboratory within four (4) weeks of the test specimens' fabrication date.

The licensee may temporarily use the certification label on a provisional basis commencing with written notification from the administrator and ending when test results are received by the administrator. (Modified 6/23/2010)

13.1.6 GAS CONTENT

A.GC.1

Any change in gas from that tested providing 1) the same gas filling fabrication process is used; argon is required for each regular testing, and 2) a one-time after weathering gas content test is done for each exotic gas other than argon (acceptable methods of test shall be GC, SES, O2 analyzer, other acceptable to IGCC®/IGMA®).(Revised 2/1/2020)

NEVER

13.2 The following situations never permit the licensee to certify with the same IGCC®/IGMA® number. They require the use of a different IGCC®/IGMA® number.

13.2.1 SPACER

N.SP.1

A change in spacer material, i.e. aluminum to steel or any other material will require a different IGCC®/IGMA® number.

N.SP.2

A change in spacer surface finish, i.e. anodized to mill finish or hot dip to electro galvanized will require a different IGCC®/IGMA® number.

N.SP.3

A change in corner design from soldered, welded, braised or bent (BC) to mechanical corner (MC) will require a different IGCC®/IGMA® number. (Modified 5/14/2008)

N.SP.4

A change in corner key material to another material, except to the same material as the spacer, will require a different IGCC®/IGMA® number. All plastic keys and joiners are considered generically equivalent. This guideline does not apply to A.SP.6. (Modified 5/14/2008)

N.SP.5

If bent, uncut spacer corners or connections (BC) are changed to mechanically fastened spacer corners (MC); a new IGCC®/IGMA® number is required. (Modified 5/14/2008)

13.2.2 DESICCANT

N.DE.1

A change in generic type of desiccant will require a different IGCC®/IGMA® number. For purpose of desiccant guidelines, the generic types of desiccant are 1) LF=Loose Fill desiccant, 2) IB=Imbedded desiccant system, 3) DM=Desiccant Matrix. (Modified 1/31/2012)

13.2.3 SEALANT

N.SE.1

In a single sealant system, a change in generic type of sealant will require a different IGCC®/IGMA® number.

N.SE.2

In a two sealant system, a change in generic type of primary sealant will require a different IGCC®/IGMA® number.

N.SE.3

In a two sealant system, a change in generic type of secondary sealant will require a different IGCC®/IGMA® number.

N.SE.4 (Deleted 9/26/2018)

N.SE.5 (Deleted 9/26/2018)

GENERAL

13.3 CLASS I - UNIT MODIFICATION

DEFINITIONS

Breather Tube - Tube inserted into the I.G. spacer that is intended to be permanently sealed at some point either prior to final glazing of the unit or by access to the end of the breather tube after glazing. This sealing is generally intended to be done after the unit is at or near its final installation elevation.

Capillary Tube - Tube inserted into the I.G. spacer and intended to be left permanently open.

Cavity Pressure Compensation Systems (CPC) - Any IG unit component or process which is designed to manage the cavity pressure of an IG unit.

CPC and How It Is Related to Membrane - IGCC®/IGMA® observes that organically sealed insulating glass units are not actually hermetically sealed, but rather are composed of sealing systems which demonstrate sufficiently low water and gas transmission rates as to pass the accelerated weathering conditions imposed in ASTM standard(s). We acknowledge that certain cavity pressure compensation system designs may also control the passage of water and gases in such a manner as to allow breathing but still demonstrate the ability to pass the test conditions.

TI = Tubes Inserted (TI units intended to be closed at some point after fabrication may be certified (durability and GCIA) if passing results are achieved. TI units intended to be left open, with no additional gas capture, shall not be GCIA certified.)

HR = Holes Resealed (Holes into the sealed airspace, created either in the field or at the factory, that are permanently sealed in the field for the purpose of cavity pressure compensation)

PA = Pressure Adjusted (Units initially made with a positive or negative preset)

RS = Relief System (Bladder or diaphragm)

PF = Post Fabrication (Designs requiring a secondary fabrication process at or near the installed altitude. Example, closing of a valve)

OT = Other (uncategorized)

G.0 Cavity Pressure Compensation (CPC) Systems

An I.G. construction incorporating a CPC system will be certified and listed (durability and gas content) as equivalent to a previously IGCC®/IGMA® program certified I.G. model without a CPC system provided the following applies: (Modified 5/4/2022)

- a) Material and construction of the units are identical, except for the inclusion of the CPC system.
- b) Both sets of I.G. units pass when tested according to ASTM standard(s) durability and gas content (GCIA) if applicable. The units with CPC system need only be tested once, but each type of CPC must be tested and will be listed accordingly (see product key). Tubes Inserted, TI units intended to be closed at some point after fabrication may be certified (durability and GCIA) if passing results are achieved. TI units intended to be left open, with no additional gas capture, shall not be GCIA certified.
- c) The test must be run by an IGCC®/IGMA® approved lab. Unit installation instruction must be supplied to the lab.
- d) Preparation of test specimens must be witnessed to ensure all fabrication steps of the CPC system process are adhered to. Evidence of an SOP shall be provided. Test results shall be submitted to and reviewed and approved by the administrator.

G.1 (Deleted 5/4/2022)

G.2 (Deleted 5/4/2022)

G.3 (Deleted 5/4/2022)

G.7 (Deleted 1/1/2007)

G.8 Internal Components (IC)

Baseline testing to ASTM E2189 shall be performed during each regular certification test on units identical to those fabricated for ASTM E2188 testing. Initially and at least each 4 years, sets of three (3) double pane, five (5) multiple cavity test specimens shall be constructed under auditor witness for E2189 internal component performance testing utilizing all the components of an internal components (IC) system, which are used in the ultimate product. Only ASTM E2189 testing shall be required in each of the following categories of internal components. The specific internal component to test in each category shall be 1) worst case product or 2) highest sales volume product, at the fabricator's discretion:

- 1) Bars, grills or muntins (BA)
- 2) Blinds (BL)
- 3) Glass, or other glazing materials (GI)
- 4) Other internal components not in the above categories (i.e. insulating materials, electronics) (OI)

When testing muntins or grills, test samples shall be fabricated dividing the sample into four areas in an off-set pattern in accordance with ASTM E2189. A licensee may use the same IGCC®/IGMA® number for units manufactured with and without internal components (IC) providing regular testing has been accomplished in accordance with the above procedure. (Modified 5/8/2019)

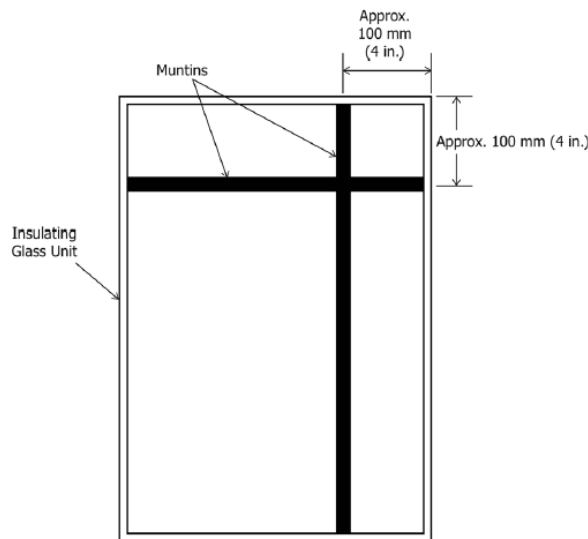

FIG. 1 Schematic Drawing of Insulating Glass Unit with Muntin Bars

G.15 Multi-Cavity

Multiple air space units may be certified with the same IGCC®/IGMA® number as single air space units, provided that the construction of each space complies with the guidelines for single space units; pressure communication of spaces is permitted, but not required. This guideline shall apply to multiple air space products that use glass or a suspended coated film (SCF) as an airspace barrier. Testing of multiple air space units shall be performed initially and in lieu of single air space unit testing at least once each (4) years. When testing multiple air space units with coated glass, the coated glass shall be on at least one outer lite for the units intended to be tested for volatile fog in accordance with ASTM E2189. (Modified 6/23/2010)

G.17 (Deleted 1/1/2007)

G.18 (Deleted 1/1/2007)

G.19 Coated Glass

An Insulating glass unit constructed with coated glass with the coating toward the air space (pyrolytic or sputter coated) shall be certified utilizing the same IGCC®/IGMA® number provided regular test units include one lite of the coated product per test sample. Only the highest volume coated product need be tested. Testing of sputter coated non-edge deleted (C3) will cover sputter coated edge deleted (C2), Pyrolytic (C1) and uncoated (U). Testing of sputter coated edge deleted (C2) will cover Pyrolytic (C1) and uncoated (U). Testing of Pyrolytic (C1) will cover Pyrolytic and uncoated (U). Testing uncoated (U) will only cover uncoated (U). When testing multiple air space units with coated glass, the coated glass shall be on at least one outer lite for the units intended to be tested for volatile fog in accordance with ASTM E2189. (Modified 6/23/2010)

G.26 Adsorption Capacity per Perimeter Foot (ACPF)

For all Certified Products and prototypes for Certification testing, the fabricator shall have on file a copy of the **Desiccant supplier's specification showing the minimum equilibrium water adsorption capacity (weight %) as measured at 25°C (77°F) and 50% Relative Humidity (+/- 5%)**. Additionally, the fabricator shall document the weight of desiccant or desiccant system (grams) in the certified product or prototype. From this data, the fabricator shall document the adsorption capacity per perimeter foot (ACPF) using the following formula: (Modified 1/31/2012)

$$\text{ACPF (grams/ ft.)} = \frac{\text{Weight of Desiccant Product (g)} \times \text{Adsorption Capacity (wt \%)}}{\text{Perimeter (Feet)} \times 100}$$

Note: For all 14 x 20 inch test specimens the perimeter is 5.66 feet

G.27 Structural Modification, i.e. Hole for Gas Fill; Electrical Connectors or Conductors

A sealed insulating glass unit that has been structurally modified, (i.e. hole or holes for gas filling (AP), connectors or conductors that penetrate the seal (primary or secondary) (SP)) shall be tested regularly for certification assembled with standard production procedures including these modifications. (Modified 5/7/2014)

G.29 IG Integrated Sash Technology

When testing IGCC®/IGMA® units using IG Integrated Sash Technology, IG fabricators would have the option of testing integrated IG units in one of two methods: 1) glass size shall be 14x20-inch and the sash shall be cut away to fit in a 14x20-inch testing opening, or 2) a larger sash which accommodates 14x20-inch glass may be tested. This option would need to be reviewed with the test lab ahead of time to ensure the test chamber can accommodate the larger sash size. All testing is completed with no glazing beads and all fabrication holes or simulated hole punches in place. If the sash is cut away, this function must be performed by the IG fabricator. (Adopted 5/3/2005)

G.30 Applied Surface Coatings to an IG Spacer and Spacer Components

An insulating glass unit utilizing an applied surface coating to an IG spacer and spacer components shall be initially certified under the normal certification testing process. The application of the coating will be documented in the product audit report. A surface coating may be added to or removed from an already certified product utilizing the same certification number by applying guideline G.5. Applied surface coatings would include, but not be limited to paints, coatings and adhesion promoters. Spacer and spacer components with an embedded or etched into the surface color are not subject to this guideline and may be certified with the same IGCC®/IGMA® number. (Modified 3/2/2011)

G.32 GCIA and Capillary and Breather Tubes and Systems

(Refer to guideline G.0) An IG construction incorporating a permanently or temporarily open system or tube, (Capillary, breather or other) may be Gas Content Initial and After Weathering certified (GCIA) with the same IGCC®/IGMA® number provided regular test units include all the components of the system or tubes. Unit installation and/or final sealing instructions must be supplied to the laboratory and performed at the laboratory. (Modified 8/6/2013)

G.34 Bent or Curved IG Units

Special note should be taken that the ASTM E2190 test method does not provide for testing of Bent or Curved IG units. As such, it is only flat IG units that fall within the IGCC®/IGMA® Certification Program. This, however, in no way precludes the ultimate use of Bent or Curved IG units. Labeled spacer may be used in IG units, other than flat glass, but in that case, certification does not apply. (Adopted 3/2/2011)

G.37 Point Support Aperture

Point support aperture units may be certified with the same IGCC®/IGMA® number as the base model, non-point support units, provided construction of the units are the same except for the point support aperture and testing of point support units shall be performed initially and in lieu of the base model, non-point support unit, at least once each (4) years. Only one point support aperture shall be present in each test unit and the center of the support shall be located 6-inches +/- 1/2-inch on the unit diagonal. Any components fixed to the IG by the IG fabricator and associated with the aperture shall be included in the test units. Changes in the shape or geometry of the through hole will not require retesting, but changes in the generic material of the seal will require retesting. (Adopted 5/4/2017)

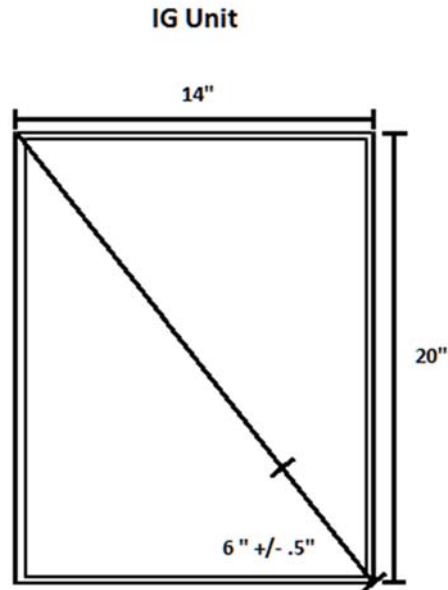

13.4 CLASS II - SPECIMEN

G.6 Specimens – Quantity

No more than 4 additional test units shall be labeled by the auditor for testing (up to 17 for double pane, VIG; and up to 19 for multiple air space.) When gas content testing (GCIA), it is recommended to ship some, or all of the additional auditor “labeled” units to the testing laboratory. (Modified 9/26/2018)

G.9 Specimens - Production (Deleted 1/1/2007)

G.10 Specimens - Production

If a licensee is not producing units at the time of an audit a labeled unit from inventory may be cut apart for inspection, provided that the date code is within the audit period.

G.11 Specimens - Production

A portion of the audit will be used to determine whether a licensee is using the IGCC®/IGMA® label on unauthorized units.

G.12 Specimens - Shipment

Units fabricated for test during an audit must be shipped directly to the approved test facility within four weeks of the date of fabrication. If they are not, the audit may be considered invalid and another audit must take place. But for normal in plant quality inspection processes performed by the manufacturer, there shall be no ‘pre-testing’ of any test sample being forwarded to the approved test facility. In situations where fabricated test units are deemed unacceptable for test by the licensee as a result of a normal plant quality inspection process, the licensee shall be allowed to re-fabricate test samples only once. This re-fabrication must occur within 45 days of the original fabrication. All costs related to this guideline are to be borne by the licensee. (Modified 5/14/2008)

G.14 Specimen Frequency

The prototype test will be considered as the test for the first year of certification (providing application is made within 12 months from the date of the test report). This is effective for matters initiated after May 1982. The next fabrication for testing purposes will be in the first half of the second year. (Modified 1/31/2012)

G.31 Suspension of Testing

There may be situations where the program participant wishes to suspend testing (gas or durability) before completion. For prototype fabrications this shall be at the discretion of the program participant and has no effect on the certification listing. For certified unit testing, with consideration for guideline G.12, any suspension of the test, gas or durability, shall be deemed as a failure of that portion of the test. G.12 would not be applicable once testing has started. (Adopted 5/14/2008)

13.5 CLASS III - EQUIVALENCY

G.5 Gray Area

Situations that are not included in the "Always" or "Never" or General categories listed above, fall into the gray area.

When there is a change and the licensee desires to use the same certification number, or desires to establish equivalency to a certified model, the licensee shall immediately notify the administrator with all details of the change and also satisfy either 1, 2 or 3 below:

- 1) Establish equivalency by passing the same level of ASTM test as certified to by having specimens tested at an independent testing laboratory. **Witness of test sample fabrication is not required but specimens must be fabricated and submitted to the laboratory within two weeks after notification of the administrator. During the test period, the licensee may temporarily use the certification label on an interim basis.**
- 2) **With approval by the administrator, establish equivalency by passing Rapid Assessment Chamber (RAC) testing. Witness of test sample fabrication is not required. Testing shall be at an approved independent testing laboratory.**
- 3) Demonstrate the equivalency of the change to the satisfaction of the Certification Committee or a subcommittee. (Specimens not required.)

G.21 Transfer

If a licensee manufactures the same model using the same technology at a different location, an IGCC®/IGMA® number with a temporary status will be issued provided that testing (durability and/or gas content) of the model is initiated at the next scheduled testing audit. (Modified 5/4/2022)

- This guideline may not be applied to products for which certification has been previously removed due to test failure.
- This guideline may be used when a plant relocates (physical relocation) under existing Ownership (IGCC shall be notified prior to plant's physical relocation).
- This guideline may be used if valid compliant test report(s) are within 12 months (one year) of the report date.

G.23 Equivalency

A licensee needs to establish equivalency for a model only once.

G.24 Vision Glass Areas

Special note should be taken that the ASTM E2190 test method only provides testing for "Vision glass areas." As such, it is only these types of units that fall within the IGCC®/IGMA® Certification Program. This, however, in no way precludes the ultimate use of these units in other applications, e.g. Spandrel units. (Adopted 8/28/1986)

Labeled spacer may be used in IG units, other than vision glass, but in that case, certification does not apply. (Adopted 4/16/1991)

G.28 Certifying Additional Constructions

A current licensee with currently certified products may certify additional constructions or replace a certified construction at the same plant location by having specimens tested at an IGCC®/IGMA® independent testing laboratory. These samples need not be witnessed by an IGCC®/IGMA® representative. Upon completion of passing test results the construction shall be eligible for IGCC®/IGMA® certification. IGCC®/IGMA® witnessed testing must occur at the next regular audit. (Adopted 7/28/1999)

G.33 Duplicate Certification

There may be situations where the program participant wishes to certify separately a model variation for which IGCC®/IGMA® would allow equivalency, both variations under a single certification number. Some examples of this duplicate certification may be dual pane and multiple air space, various moisture vapor transmission path lengths (sightlines), variations in coated glass. This duplicate certification shall be allowed and each variation given a separate certification number. Each certification number will be treated as its own certified model and be subject to normal product fees, testing and auditing requirements.

G.35 Multiple Sources of Same Generic Category

If a licensee regularly uses multiple sources of supply within the same generic category each source of supply (A and B) shall be tested on a rotational basis. If one source of supply (A) is tested and fails to comply, the same source of supply (A) must be tested to maintain certification for that source of supply. If certification for (A) is no longer required by the licensee the retest due to failure must still occur with (B) or a new alternate source of supply (C). (Modified 8/6/2013)

G.36 Sale of Plant and Transfer to New Ownership

When a fabrication facility (plant) with a currently certified IGCC/IGMA product, or pending prototype(s), is sold to new owners, the certification may be transferred to the new owners. The following steps shall be followed for the new owners and plant to maintain IGCC®/IGMA® certification: (Adopted 5/4/2017)

- 1) Notify the Administrative Office, in writing, when the sale is to take place or when sale is finalized. Notification shall include a description of any interruptions in production or changes that may affect the status of certification, including product

marking.

- 2) A new license agreement shall be signed and returned to Administrative Office, if the new owner is a new licensee.
- 3) The new owner shall be responsible for any outstanding certification and testing fees unpaid.
- 4) While it is encouraged for the new owners to utilize new IGCC/IGMA certification numbers, retention of the same certification number(s) from the prior owner shall be allowed. Regardless of prior testing history, testing will need to be completed during the next regular facility visit.
- 5) The above is only applicable if a majority of plant personnel and fabrication equipment is maintained. New prototype testing may be necessary if significant changes are made.

G.38 Inactive Certification

After initial certification, a licensee, with multiple certified products, may place a different (non-equivalent) certified product into an “inactive status”. During inactive status, directory listing would still occur but with an “IN” designation. Regular retesting would not be required. Returning to a “Certified” status and labelling of production units would not be allowed without notification of the Administrative office. When returned to “Certified” status, an audit and witness fabrication of retest specimens must occur within 45 days of reactivation, unless current test reports are within one year of the report date. A product may only remain in “IN” for up to 5 years. (Modified 9/26/2018)

13.6 CLASS IV - APPEALS, REVIEW AND DE-CERTIFICATION

G.13 Monetary

The administrator shall remove authorization to use the IGCC®/IGMA® permanent label from all of any licensee’s products for failure to pay monies due to IGCC®/IGMA® within 60 days of invoice date (reference License Agreement A. 13 and B.6).

G.16 Failure to Comply

In cases where a routine test fails to comply with the specifications: (Modified 2/4/2015)

- 1) Upon notification of failure of routine test samples to reach the certified level, the licensee will be officially notified. Within 15 days the licensee must respond to the certified letter stating a retest fabrication is requested. If there is no response within 15 days, authorization to use the IGCC®/IGMA® permanent label will be removed. If the retest option is accepted:
 - a) Request for retest option is granted by IGCC®/IGMA® only upon receipt of notification of retest within 15 days of date of mailing of the notification of failure.
 - b) IGCC®/IGMA® will perform an audit and witness fabrication of retest specimens within 45 days of the date of program notification.

- c) Licensee must ship and pay any and all administrative and testing fees retest specimens to the testing laboratory within 4 weeks of fabrication.
- 2) There is to be no change in certification status during the retest period. All routine audits will continue. Sample fabrication for subsequent routine testing of the questionable model will be suspended pending the outcome of the retest.
- 3) If the retest units comply, they shall be considered as the next routine test.
- 4) If the retest units fail, the licensee is issued a cease and desist order on use of the label immediately.
- 5) The licensee may choose to accept certification at any level passed by the retest, although it might be a lower level than originally desired.

G.20 Authorization to use the IGCC®/IGMA® Permanent Label

Authorization to use the IGCC®/IGMA® permanent label will be removed if a routine audit discloses that a licensee is labeling units containing the same unauthorized construction for the third time.

G.22 Clarification of Due Process Appeal Process

Clarification of due process appeal process under License Agreement, Paragraph A.11:

A Licensee's appeal from a final adverse decision by the Administrator, under License Agreement Paragraph A.11, shall in the first instance be to the Certification Appeals Subcommittee of the Certification Committee, which acts as an executive committee for the Certification Committee in order to provide a prompt hearing for the Licensee and to act on the Licensee's appeal as quickly as possible. A decision by the Certification Appeals Subcommittee favorable to the Licensee shall be a final decision. A decision by the Certification Appeals Subcommittee adverse to the Licensee may be appealed to the full Certification Committee for a due process review and hearing. Such an appeal to the Certification Committee must be made in writing within 30 days of an adverse decision by the Certification Appeals Subcommittee and this appeal will be heard at the next meeting of the Certification Committee. Pending a hearing by the Certification Committee on such an appeal, the Licensee may maintain certification for the product at issue.

Committee rule to clarify guideline G.22 as adopted by the Certification Committee at minute 10.31.12.10

The Chairman of the Certification Committee may call for a special meeting of the Committee (with notice provided in the same way as for a special meeting of the Board of Governors under the Bylaws), and the Committee may conduct a special meeting (at the physical location identified in the notice or by use of conference telephone or other communication equipment by means of which all persons participating in the meeting can communicate with each other), with such special meeting to be at a date and time other than the next regularly

scheduled meeting of the Committee, and at which special meeting any proper business of the Committee, including business under Procedural Guideline G.22, may be conducted. (Modified 10/31/2012)

SPECIFICATION USED FOR SEALED INSULATING GLASS

- **ASTM E2188**
- **ASTM E2189**
- **ASTM E2190**
- **ASTM E2649**

Specification may be obtained by contacting:

ASTM

100 Barr Harbor Drive

West Conshohocken, PA 19428-2959

Telephone: (610) 832-9585

Web Address: www.astm.org

Adopted: May 13, 1977
Revised: August 1, 1981
Revised: January 15, 1986
Revised: January 17, 2012

IGCC® STANDARD PARTICIPANT’S AGREEMENT APPLICABLE TO “SUPPLIER” (NON-IG UNIT MANUFACTURER), “PUBLIC INTEREST”, “TEST LABORATORY”, “TRADE ASSOCIATION”, IG-UNIT “USER”, “OTHER PERSON/ORGANIZATION WITH LEGITIMATE INTEREST” OR “CONSUMER” PARTICIPANTS IN IGCC®

This Agreement, made and effective this _____ day of _____, 20____, by and between _____ (hereinafter called “PARTICIPANT”) and INSULATING GLASS CERTIFICATION COUNCIL, INC. (hereinafter called IGCC®), an Illinois not-for-profit tax-exempt corporation having its administrative office at 205 West Main Street, Sackets Harbor NY 13685, hereby provides as follows:

In consideration for being approved as an IGCC® Program Participant, and for the right to vote under the IGCC® Corporate Bylaws as an IGCC® Program Participant, I attest and agree, personally or on behalf of my employer, as follows:

A. IGCC Corporate Bylaws: I attest that I have read the IGCC ® Corporate Bylaws and that I or my employer have a legitimate interest in the goals of IGCC®, and I agree, personally or on behalf of my employer, to be bound by the IGCC® Corporate Bylaws.

B. Eligibility and Participant Category: I attest as follows, personally or on behalf of my employer, and request to be recognized, either personally or on behalf of my employer, as a PARTICIPANT in IGCC® in one of the following participation categories: Supplier (Non-IG Unit Manufacturer); Public Interest; Test Laboratory; Trade Association; IG-Unit User; Consumer; Other person/organization with legitimate interest in the purposes of the IGCC® corporation: _____ (Please indicate category).

1. I understand that IGCC®-approved test laboratory participants conducting tests in the IGCC® Certification Program also sign and are obligated to follow the provisions of the IGCC® standard test laboratory agreement, and that IGCC® IG-Unit manufacturer licensee-participants sign and are obligated to follow the provisions of the IGCC® standard license agreement for IG-unit manufacturers, and become participants in IGCC® thereby.

2. I attest that I do not manufacture IG-units nor am I employed by an IG-unit manufacturer (as such, neither I nor my employer qualify to become an IGCC®-IG Unit manufacturer-licensee). If my Participant category or eligibility changes (e.g. by beginning fabrication of IG units), this Agreement will be null and void.

C. Annual Fee: The annual fee for a Supplier (Non-IG Unit Manufacturer) Participant is \$350.00 per company (as of 1/17/2012), subject to change by the IGCC® Board of Governors. There is no fee for public interest or consumer participants. On behalf of my employer, I agree this annual fee for a Supplier Participant (Non-IG Unit Manufacturer) in IGCC® shall be payable upon receipt of an invoice and shall be non-refundable.

D. Voting Rights and Responsibilities: (1) I understand and agree the IGCC®/IGMA certification program is structured and operated such that program policies and decisions are made in open parliamentary due-process committees whose meetings and actions shall be conducted with impartial review and implementation governance and administrative process. (2) I understand and agree that the IGCC® Certification Committee, as the primary working committee in which I may cast a vote as a Participant (if eligible under the Bylaws), shall operate free from commercial, financial or other interests that might conflict with IGCC's best interests and goals as set forth in IGCC's Corporate Bylaws, and I shall recuse myself from casting any vote in which a conflict of interest may exist. (3) I understand and agree that members of the Certification Committee provide a balance of interests where no single interest dominates. (4) I understand and agree each Participant is responsible for maintaining the confidentiality of specific information as may be requested and appropriate. (5) I understand and agree that the IGCC Board of Governors has ultimate governance authority under the IGCC Corporate Bylaws and applicable law, and that IGCC Participants and Participants' meetings are governed specifically by IGCC Corporate Bylaws Articles III and IV.

E. Dispute Resolution Process: I agree, personally or on behalf of my employer, to the following dispute resolution process, which is the same dispute resolution process applicable to IGCC® IG-Unit Manufacturer-Licensee Participants under the IGCC® standard license agreement for IG-Unit Manufacturers:

Any claim, complaint, dispute or related controversy asserted by me or my employer arising out of or regarding participation in IGCC® under this Agreement, or the operation of IGCC® under the IGCC® Corporate Bylaws, including the determination of the scope or applicability of this Agreement, and any arbitration pursuant to this standard IGCC® Participant's Agreement, shall be governed by the laws of the State of Illinois and the Illinois Not-for-Profit Corporation Act (under which IGCC® is incorporated), and the parties to this IGCC® Participant's Agreement agree that any such claim, complaint, dispute or related controversy not settled amicably between the parties will be resolved exclusively by submitting any such claim, complaint, dispute or related controversy (following a mandatory 20 day period in which no claim, complaint, dispute or related controversy shall be submitted to arbitration and during which the parties will seek a mutually agreeable resolution of any claim, complaint, dispute or related controversy) to binding contract arbitration, unless both parties consent to mediation or some other form of dispute resolution. In the event of contract arbitration, the arbitration will be conducted by a neutral third party arbitrator accepted by both parties. In the event that the parties do not agree to the appointment of any arbitrator, any claim, complaint, dispute or related controversy asserted by me or my employer regarding participation in IGCC® under this Agreement, or the operation of IGCC® under the IGCC® Corporate Bylaws, shall be resolved under the most-current Commercial Arbitration Rules of the American Arbitration Association. The place of the arbitration shall be in Illinois or some other mutually agreeable location. In any arbitration proceeding, reasonable discovery of evidence shall be allowed, and strict conformity to legal rules of evidence shall not be necessary, and the parties may offer evidence as is relevant and material to the dispute, which shall be considered in the arbitrator's reasonable discretion. The arbitrator, exercising his or her discretion, shall conduct the proceedings with a view to expediting the resolution of the claim, complaint, dispute or related controversy. The prevailing party in the arbitrator's Decision and Final Award shall be entitled to recover reasonable attorney's fees and costs it may incur in connection with the arbitration

proceeding. The arbitrator's Decision and Final Award shall be enforceable in any court of competent jurisdiction.

F. To maintain or commence Participant status, this Agreement needs to be signed by Participant. This Agreement supersedes and replaces any predecessor IGCC® Standard Participant's Agreement to which I or my employer is a party.

SIGNED and DATED:

PARTICIPANT: _____
Please sign and print name and title/authority; and date

Company/Business/Organization Name: _____

Street Address: _____

Telephone Number: _____; Fax Number: _____

Email Address: _____; Website: _____

Primary IGCC® Program contact for Participant: _____ (Please print)

APPROVED and AGREED:

INSULATING GLASS CERTIFICATION COUNCIL, INC. (IGCC®)
P.O. Box 730, 205 West Main Street, Sackets Harbor, NY 13685
Telephone: (315) 646-2234 Fax: (315) 646-2297 Email: staff@amscert.com

By: _____ (Please sign and date _____)
John G. Kent, IGCC® Administrative Manager

* A copy signed by IGCC® will be returned to Participant



AMS, INC.
Administrative Management
Systems, Inc.

205 West Main, PO Box 730
Sackets Harbor, NY 13685
Phone: (315) 646-2234
Fax: (315) 646-2297
E-mail: IGCC@amscert.com



**STANDARD LICENSE AGREEMENT FOR AMS CERTIFICATION UNDER IGCC®/IGMA®
CERTIFICATION PROGRAM FOR SEALED INSULATING GLASS UNITS
(ID-30)**

(as revised effective September 16, 2019, and constituting the successor effective agreement, pursuant to the terms herein, for all preceding fully-executed IGCC®/IGMA® Certification Program standard license agreements)

This Agreement, made this _____ day of _____, 20____, by and between Administrative Management Systems, Inc. (AMS), a New York corporation, hereinafter called "LICENSOR", and INSULATING GLASS CERTIFICATION COUNCIL, INC, (hereinafter "IGCC®" or PROGRAM SPONSOR), an Illinois not-for-profit tax-exempt corporation each having their office at 205 West Main St. P.O. Box 730, Sackets Harbor, NY 13685, and (legal entity) _____ having its principal office at (location) _____, (hereinafter called "LICENSEE"), hereby provides as follows:

WITNESSETH:

1. WHEREAS, Licensor is the certification body for the certification program noted below and as designated in the attached addendum(s) and hereinafter referred to as the Certification Program, sponsored by designated Program Sponsor for Sealed Insulating Glass Units, which will provide for (1) the validation of a manufacturers certification of such products by means of independent laboratory testing and evaluation to the requirements of applicable Specification(s) and applicable Test Method(s) and ASTM Standards; and under the further terms and conditions of the Certification Program set forth in this Agreement and the Program's Procedural Guide, and also providing for (2) the stipulation by each such manufacturer that the manufacturer maintains a quality assurance program which covers the production of all the units to which this agreement refers; and
 2. WHEREAS, the term "Sealed Insulating Glass Certification Program(s)" as used herein refers to the sealed insulating glass certification program as designated and described in greater detail in the Addendum(s) which are attachment(s) to this Standard License Agreement and hereby made a part thereof;
 3. WHEREAS, The responsibilities of the Licensor and Program Sponsor are limited to the tasks set forth in this Certification Program Standard License Agreement and any requirements as may be necessary to maintain accreditation to applicable standards; Licensor and Program Sponsor do not endorse, warrant, or guarantee products validated or certified under the Certification Program, and
 4. WHEREAS, Licensor and Program Sponsor are willing to accept participation in said Certification Program by all manufacturers of Sealed Insulating Glass Units under the terms set forth herein; and

5. WHEREAS, Program Sponsor is the uncontested sole owner of the designated program mark and label IGCC®; the aforesaid mark/label, and/or other mark(s)/label(s) cross-licensed to Program Sponsor IGCC® are hereby licensed by Program Sponsor to Licensor (AMS), which has entered into a valid service agreement with Program Sponsor IGCC® for authorization of use of the mark, and which mark(s) is/are hereby licensed by Licensor and Program Sponsor to Licensee and said label(s)/mark(s) shall be permitted to appear on Licensee's registered Certification Program marks/labels which are permitted by Licensor to be affixed to the Sealed Insulating Glass Units complying with the pertinent requirements of the Certification Program; and
 6. WHEREAS, the Licensor and Program Sponsor may contract for services with independent laboratories which have signed and meet the requirements of the Testing Laboratory Agreement, and with auditors and other service providers deemed necessary for the operation of the program who have entered into a valid agreement ; and
 7. WHEREAS, the Program Sponsor shall appoint a "Certification Committee" which shall be structured and operate in accordance with the requirements of the IGCC® By-laws: meetings of this committee shall be called by the Chairman of the Certification Committee at least once each year; and
 8. WHEREAS, the procedural guide shall be adhered to by the Licensor, Program Sponsor and the Licensee; and
 9. WHEREAS, the Licensor shall conduct all aspects of the program in accordance with standards and accreditation requirements that may be identified by the certification program, this license agreement, the procedural guide and program documents and procedures; and

10. WHEREAS, Licensee is willing to participate in and support said Program under the terms and conditions set forth in this Agreement.

Therefore, be it
RESOLVED, that it is agreed by and between the parties hereto as follows:

LICENSEE:

A.1) Shall sign this Agreement by providing the signature of its corporate officer or authorized representative, and also its primary Certification Program contact, where noted herein.

A.2) Shall allow the Licensor's representative, and observers from accreditation bodies or program sponsor without prior notice, free access at any time during regular business hours, to Licensee's place of manufacture of Sealed Insulating Glass Units certified hereunder and to witness the manufacture of samples which are to be tested for compliance with the requirements. Licensee's refusal to permit access for audit purposes hereunder is cause for removal of its entire product listing from the Certified Products Directory and the withdrawal of its rights to affix Certification Marks/Labels thereto. Acceptable reasons for not permitting entrance for audits would include strikes, acts of God, and circumstances beyond immediate control of the manufacturer. Areas which may have been set aside for research or prototype development may be restricted. It is understood that the Licensor or his representative shall be allowed to pick up samples from the field for audit or testing. It is understood that periodic tests will be made on each model to be certified and that said tests will be made at the laboratory selected by the Licensor or Licensee from the approved list. Licensor will notify the Licensee of compliance or non-compliance. It is further understood that routine expense of sampling and testing will be borne by the Licensee. The Licensor will charge each Licensee accordingly and so contract for applicable services. Expenses for packaging, shipping, and purchasing of glass for testing will also be borne by the Licensee.

A.3) Shall affix to each of its certified products the permanent Certification Mark/Label assigned by the Licensor:

- a) Only at the time and place of manufacture; and
- b) Only to Sealed Insulating Glass Units of Licensee's own manufacture, which have been so approved by the Licensor.

A.4) Shall not sell, transfer or otherwise dispose of Certification Mark/Labels in any manner other than affixing to Licensee's certified production.

A.5) Shall not affix hereafter the Certification Program registered mark, or Participant's Certification Mark/Label registered with Licensor, to any product from which certification has been withdrawn or which is produced with a process basically different from the one used when certification was obtained. A model change shall be as defined by the certification program.

A.6) Shall upon a finding by the Licensor that a certified product of Licensee has been changed as defined by the Certification Committee have thirty (30) days in which to submit a request for waiver of retest or request a new audit and retest at Licensee's expense if no waiver is granted. Failure of Licensee to act as required immediately above shall constitute due cause for exclusion of this product from the program.

A.7) May withdraw a certified product from the Program by written declaration and request for removal of said product from the Licensor's listing signed by the authorized representative of the Licensee.

A.8) Shall use all practical means at its command continuously to assure that its products hereunder certified fully comply with the Specification requirements, and are manufactured in the same manner as test specimens, and are subject to a quality assurance program maintained by Licensee, and Licensee shall so stipulate to the Program Sponsor's representatives during the periodic visits of said representatives to Licensee's facilities, or when otherwise requested

by the Program Sponsor or Certification Body. Licensee shall also fulfil the certification requirements, including implementing appropriate changes when they are communicated by the Program Sponsor or Certification Body; if the certification applies to ongoing production, the certified product continues to fulfil the product requirements in accordance with Program Guidelines.

A.9) Shall refrain from using terms implying or claiming certification, validation, accreditation, or the like in connection with advertising referring to products which have not been certified, or from which validation of certification claim has been suspended, withdrawn, or terminated.

A.10) In connection with the advertising of model systems which the Licensor has approved and granted a certification number or mark/label, the Licensee must use the following concepts as guidelines: Licensor (AMS) is the Certification Body or certifier, (IGCC®) the Certification Program Sponsor. Licensee (Manufacturer) certifies that the product is the same as the model which has been tested. Licensor validates the test results through Audits according to the certification program guidelines.

A.11) Shall abide by the decision of the Licensor as to the conformance or non-conformance of Licensee's products with the requirements of the Certification Program, determined in accordance with the requirements of the specification testing and quality assurance requirements as defined by the Certification Program. It is understood that the Licensor shall be the sole judge of conformance or non-conformance with the Specifications applicable to the Certification Program, for purposes of Licensor's validation of Licensee's certification of such a product under this Program. Where questions involving interpretation arise, the matter will be referred to the Program Sponsor for ruling.

A.12) Agrees that notice regarding the status of any of its certified products shall be carried in the Certified Products Directory maintained by Licensor on behalf of Program Sponsor.

A.13) Shall pay the participation fees shown in the Schedule of Fees, current version, upon signing of this Agreement and at each regular renewal thereof. It is understood, that this Schedule of Fees may be changed from time to time by the Licensor and Program Sponsor.

A.14) Agrees that the Licensor may, at his discretion, use any and all data, exclusive of Licensee's Company name, address, proprietary product designation or any other information which may provide clues as to the manufacture of the products, for the purpose of comparing test methods and correlating test methods with field performance.

A.15) Shall legibly and permanently mark or label each certified product in accordance with the current label requirements of the certification program, which may be changed from time to time.

A.16) Shall furnish Licensor with any information regarding its product as may be necessary to properly identify Licensee's Certified Product for listing in the Certified Products Directory.

A.17) Shall regularly mail to the Licensor, at the same time as such material is furnished others, copies of its catalogs and other literature, excluding price and discount information, where such materials list Licensee's products certified hereunder. The Licensee shall not reference its product certification in a manner as to bring the Licensor or Program Sponsor into disrepute and shall not make statements regarding its product certification that may be considered misleading or unauthorized. If certification documents are provided to others, the documents shall be reproduced in their entirety.

A.18) Shall abide by and comply with all procedural details which the Licensor and Program Sponsor may prescribe for the implementation of the Certification Program, provided that such procedural details are not inconsistent with the provisions and purposes of this License Agreement.

A.19) Shall have the right, at its option, to designate a nominee from Licensee's organization for consideration for appointment to the IGCC® Certification Committee.

A.20) Shall notify Licensor without delay, of any changes that may affect its ability to conform with the Certification Program requirements;

A.21) Shall in making reference to product certification in communication media such as documents, brochures, or advertising, including websites, comply with Certification Program requirements;

A.22) Shall keep a record of all complaints made known to it relating to compliance with certification requirements and makes the records available to the Licensor when requested, and

- 1) Take appropriate action with respect to such complaints and any deficiencies found in products that affect compliance with the requirements for certification;
- 2) Document the actions taken

LICENSOR AND PROGRAM SPONSOR:

B.1) Shall prepare and publish at least twice each year, with such interim supplements as may be desirable, a Certified Products Directory (hard copy and/or electronic) containing a listing of the Certified Insulating Glass Products which have been found by testing and audit of quality assurance programs to be in compliance with each required specification for each Licensee then in good standing with Licensor and Program Sponsor. This directory shall include the Licensee's assigned certification number, name, location and product certification status.

B.2) Shall promptly distribute (hard copy and/or electronic) substantial quantities of each Directory and supplement to door, sash, and building products manufacturers, glazing contractors, home builders, architects, regulatory agencies and code-making groups, and publicize the Directory to trade publications.

B.3) Shall provide and maintain a list of approved laboratories qualified to perform tests required hereunder and to authorize tests herewith specified. Said list of approved laboratories is to be developed by the IGCC® Certification Committee.

B.4) Shall prepare and maintain a procedural guide and the standard forms which may be adopted for use with the Licensee and the approved laboratories in connection with the operation and program requirements of the Certification Program, including the testing and quality assurance requirements thereof.

B.5) Shall hold all test reports and correspondence with Licensees and others, relating to Licensee's products or tests, in strict confidence, except for communication necessary to effect proper listing in the Certified Products Directory, communication necessary to effect any program approvals or accreditation, and as required by law.

B.6) Shall not list in or remove from the Certified Products Directory any product or Licensee except on due notification in writing from an authorized representative of the Licensee or because Licensee fails to pay applicable fees as provided in the most current Schedule of Fees.

B.7) Shall administrate the Certification Program to provide and authorize all sampling and testing, review and approve test data, perform periodic evaluations or other duties and functions herein provided for including granting maintaining, extending, suspending or withdrawing certification.

IT IS FURTHER AGREED THAT:

C.1) A certification test hereunder denotes and is limited to a test in accordance with the requirements of the appropriate specifications and related test methods.

C.2) Each branch or affiliated plant of each Licensee manufacturer must be registered individually, and products therefrom tested and certified separately and apart from products manufactured in other plants or branches of any Licensee manufacturer.

C.3) A procedure exists for handling appeals and complaints and may include complaints of non-conformance which provides for samples of like product to be provided by Licensee in a specified manner for repetition of tests within thirty (30) days, the total cost of which, including test specimens, is to be borne by the complainant, unless the test proves non-conformance, in which case the costs will be borne by the Licensee; tests are to be initiated by the Licensor promptly upon receipt of a complaint in writing along with the appropriate surety deposit. Complaints and Appeals regarding the Certification Program that cannot be resolved by Licensor shall be resolved by the Program Sponsor.

C.4) This agreement shall become effective on the date of signing and shall extend for a period of 12 months and shall be renewed automatically for successive periods of 12 months each, and remain in effect unless Licensor, Program Sponsor or Licensee, at least sixty (60) days prior to the date of expiration, gives notice in writing that cancellation or termination is requested (which shall be deemed agreed and effective at the conclusion of said notice period) and unless revoked and terminated by Licensor or Program Sponsor for causes set forth in this Agreement and in accordance with procedures set forth in the Agreement and the Certification Program Procedural Guide.

C.5) If this agreement is terminated, then upon the effective date of such termination, Licensee shall:

- a) Not affix the registered quality Certification Mark/Labels to any product which Licensee shall thereafter manufacture; and
- b) Make no further reference to, or use of, Licensor's certification or Program Sponsor's Certification Program or registered Certification Mark/Labels as used earlier in the Certification Program.

C.6) Licensor, in the event it shall be necessary to exclude Licensee from participation in the Certification Program in accordance with the provisions hereof, may do so by giving Licensee thirty (30) days written notice of Licensor's termination of the License Agreement.

C.7) The terms of this Agreement and any disputes arising from or about this Agreement, and any arbitration pursuant to this Agreement, shall be governed by the laws of the State of Illinois, in which the program sponsor is incorporated. The parties agree that all disputes relating to the interpretation of, or otherwise about or arising from the terms of this Agreement not settled amicably between them will be submitted (following a mandatory 20 day period in which no claim shall be submitted to arbitration and during which the parties will seek a mutually agreeable resolution of any claim or dispute) exclusively and solely to binding contract arbitration, unless each party consents to mediation or some other form of dispute resolution. In the event of contract arbitration, the arbitration will be conducted by a neutral third party arbitrator accepted by each party. In the event that the parties do not agree to the appointment of any arbitrator, any controversy or claim arising out of or relating to this contract, or the breach thereof, shall be resolved under the most-current Commercial Arbitration Rules of the American Arbitration Association. The place of the arbitration shall be in Illinois, or some other mutually agreeable location. In any arbitration proceeding, reasonable discovery of evidence shall be allowed, and strict conformity to legal rules of evidence shall not be necessary, and the parties may offer evidence as is relevant and material to the dispute, which shall be considered in the arbitrator's reasonable discretion. The arbitrator, exercising his or her discretion, shall conduct the proceedings with a view to expediting the resolution of the dispute. If any party submits an arbitration claim to enforce any of the terms of this Agreement, the prevailing party shall be entitled to recover reasonable attorney's fees and costs it may incur in connection with the arbitration proceeding. A final award by the arbitrator shall be enforceable in any court of competent jurisdiction.

C.8) In the event any part or parts of this Agreement are found to be void, the remaining provisions shall nevertheless be binding with the same effect as though the void parts were deleted.

C.9) The use of any Mark/Label governed by this Agreement on any unqualified product, or the use of any such Mark/Label by a manufacturing or assembly or other facility other than that registered will not be permitted by the Licensee, its employees, its representatives, and its agents. If the use of any Mark/Label in contravention of this Agreement is discovered, after a due process hearing review by the Certification Committee, the Licensor and Program Sponsor will have cause to institute or seek all or any of the following actions: a) Revocation of license; b) Imposition of an award in favor of Licensor or Program Sponsor of liquidated damages of five thousand dollars (\$5,000); c) Legal action preventing the Licensee from having the applicable Mark/Labels printed, attached, or used in any manner by Licensee, with the entire cost of such legal action to be borne by the Licensee.

C.10) In the event Licensor promptly notified all those to whom it has sent the then most recent issue of the Certified Products Directory or supplement thereto, as well as the National Better Business Bureau and the trade press, regarding any incorrect listing or reference to Licensee's product(s) published in any Certified Products Directory, supplement thereto, or elsewhere, Licensee agrees not to hold Licensor or Program Sponsor liable in any way for any damage caused by such incorrect listing or reference, unless such damage was the result of an intentional tort, willful act or gross negligence by Licensor or Program Sponsor.

C.11) Licensee shall indemnify and hold Licensor and Program Sponsor harmless as to any expense whatsoever for, or incurred in

connection with, any claims, losses, or defense of claims or losses, which may be asserted by a third party against Licensor and Program Sponsor by reason of this Agreement and services performed hereunder,

C.12) No party shall make use of the others' trademarks, trade names or name in any manner without the prior written approval of the other provided each party hereby authorizes the other, during the term of this Agreement, to state that the Licensee is a participant in this Certification Program.

THIS LICENSE AGREEMENT may not be transferred, assigned, or otherwise disposed of to any other company, individual, or successor company without the express prior written consent of the Licensee, Licensor, and Program Sponsor.

By mutual agreement of Licensee, Licensor, and Program Sponsor, THIS AGREEMENT supersedes and replaces the predecessor IGCC® Standard License Agreement, in the form executed between the parties, if Licensor, Program Sponsor and Licensee have executed any such predecessor IGCC® Standard License Agreement. If such a predecessor agreement was executed, that predecessor agreement is hereby cancelled, by mutual agreement, effective as of execution of THIS AGREEMENT (which is a successor standard agreement to the earlier IGCC® Standard License Agreement), with the 60 days notice of cancellation period for the predecessor agreement hereby waived by Licensee.

LICENSEE: Company _____
Street Address _____
City, State and Zip _____
Telephone Number _____

Signed By _____ Title _____
(Corporate Officer or Authorized Representative)
E-Mail Address: _____ Date _____

Signed By _____ Title _____
(Primary IGCC® Certification Program Contact)
E-Mail Address: _____ Date _____

LICENSOR: Administrative Management Systems, Inc. (AMS)

By _____ Title President
Date _____

PROGRAM SPONSOR: Insulating Glass Certification Council, Inc. (IGCC®)

By _____ Title Administrative Manager
Date _____

AMS/IGCC
P.O. 730 205 West Main St.
Sackets Harbor, NY 13685
Telephone: (315) 646-2234 E-mail: IGCC@amscert.com

***A COPY SIGNED BY LICENSOR AND PROGRAM SPONSOR WILL BE RETURNED TO LICENSEE.**

Addendum

Where referenced "Sealed Insulating Glass Certification Program" refers to the below certification programs.

IGCC®/IGMA® Program

On February 3, 2009 the IGCC® Certification Program and IGMA® Certification Program were combined into one program called the IGCC®/IGMA® Certification Program in a formal documented agreement called the ADMINISTRATION SERVICES AND EXCLUSIVE LICENSING AGREEMENT.

The IGCC®/IGMA® ADMINISTRATION SERVICES AND EXCLUSIVE LICENSING AGREEMENT names Insulating Glass Certification Council (IGCC®) responsible for governance of IGCC®/IGMA® Certification Program. As such, the following responsibilities for the IGCC®/IGMA® Certification Program are:

Program Sponsor: IGCC® Insulating Glass Certification Council
Program Administrator and Certification Body: Administrative Management Systems, Inc.

Relevant and Applicable Requirements:
IGCC® Procedural Guide and Standards
IGCC®-IGMA® Certified Products Directory

**IGCC®/IGMA® APPROVED LABORATORIES PRESENTLY CONDUCTING
TESTS IN ACCORDANCE WITH ASTM E2190 & E2649 (ID-151)**

Participants in the program may choose any laboratory from the approved lab list.

California	Pennsylvania
<p>125 - Architectural Testing Inc. (an Intertek Company) Architectural Testing Inc. (an Intertek Company), 2524 East Jensen Ave.; Fresno, CA 93706 Attn: Kenny White, Mr. Joshua Lannum, Mr. Tyler Westerling, Ms. Marisela Saavedra, Ms. Shannon Stein Phone: (559) 233-8705 Fax: (559) 233-8360 Email: kenny.white@intertek.com, joshua.lannum@intertek.com, Tyler.Westerling@Intertek.com, Marisela.Saavedra@Intertek.com, Shannon.Stein@Intertek.com</p>	<p>911 - Molimo, LLC. Molimo, LLC., 1410 Eden Road; York, PA 17402 Attn: Mr. Lance Cunningham, Mr. Joseph Descheemaeker, Mr. Michael Stremmel, Mr. Nathaniel Young Phone: 717-916-6300 Fax: 717-318-5788 Email: lcunningham@molimo.com, jDescheemaeker@molimo.com, mstremmel@molimo.com, nyoung@molimo.com</p>
Florida	Texas
<p>850 - PRI Construction Materials Technologies PRI Construction Materials Technologies, 6412 Badger Dr; Tampa, FL 33610 Attn: Tim Efaw Phone: 813-621-5777 Fax: 813-621-5840 Email: tim.efaw@pri-group.com</p>	<p>175 - Architectural Testing Inc. (an Intertek Company) Architectural Testing Inc. (an Intertek Company), 1909 10th Street, Suite 100; Plano, TX 75074-8009 Attn: Mr. Fred Munoz, Mr. Jacob MacMaster, Cassandra Matthews Phone: (469) 814-0687 Fax: Email: lucio.munoz@intertek.com, Jacob.MacMaster@intertek.com, cassandra.matthews@intertek.com</p>
Minnesota	Washington
<p>150 - Architectural Testing Inc. (an Intertek Company) Architectural Testing Inc. (an Intertek Company), 40 51st Way NE Suite 100; Fridley, MN Attn: Mr. Lukas Bayer, Ms. Wendy Allison Phone: (651) 636-3835 Fax: (651) 636-3843 Email: lukas.bayer@intertek.com, Wendy.Allison@intertek.com</p>	<p>195 - Architectural Testing Inc. (an Intertek Company) Architectural Testing Inc. (an Intertek Company), 22155 68th Ave. South; Kent, WA 98032-1937 Attn: Mr. Dauda Sanoh, Ms. Rachel Pankaskie, Mr. Kal Kooner Phone: (253) 395-5656 Fax: (717) 764-4129 Email: dauda.sanoh@intertek.com, rachel.pankaskie@intertek.com, Kal.kooner@intertek.com</p>
Pennsylvania	Canada
<p>100 - Architectural Testing Inc. (an Intertek Company) Architectural Testing Inc. (an Intertek Company), 130 Derry Court; York, PA 17406-9405 Attn: Intertek York IGCC, Mr. Cory Straub, Amanda Ashby, Mr. Thomas Mickley, Mr. Travis Hoover Phone: (717) 764-7700 Fax: (717) 764-4129 Email: yorkiggroup@intertek.com, cory.straub@intertek.com, amanda.ashby@intertek.com, tom.mickley@intertek.com, Travis.Hoover@Intertek.com</p>	Ontario
<p>800 - National Certified Testing Labs (NCTL) National Certified Testing Labs (NCTL), 5 Leigh Drive; York, PA 17406 Attn: Mr. Justin Bupp, Drew Klinedinst Phone: (717) 846-1200 Fax: (717) 846-1200 Email: jbupp@nctlinc.com, DKlinedinst@nctlinc.com</p>	<p>50 - Element Materials Technology Canada Inc. Element Materials Technology Canada Inc., 2395 Speakman Drive; Mississauga, ON L5K 1B3 Attn: Michael Barrera, Mr. Joe DeRose, Mr. Jordan Church, Mr. Mark Balonzo Phone: +1 (905) 822-4111 Fax: +1 (905) 823-1446 Email: Michael.Barrera@element.com, joe.derose@element.com, jordan.church@element.com, Mark.Balonzo@element.com</p>

IGCC®/IGMA® APPROVED LABORATORIES PRESENTLY CONDUCTING TESTS IN ACCORDANCE WITH ASTM E2190 & E2649 (ID-151)

Participants in the program may choose any laboratory from the approved lab list.

Canada

Ontario

60 - CAN-BEST

CAN-BEST, 38 Regan Road, Unit 4 ; Brampton, ON L7A 1C6

Attn: Elie Alkhoury, Ms. Brenda Da Silva

Phone: 905-840-2014 Fax: 905-840-2847

Email: elie@can-best.com, brenda@can-best.com

China

55 - China National Safety Glass

China National Safety Glass, 1# Guanzhuang Dongli, Chaoyang District; Beijing 100024

Attn: Wang Geng, Ms. Wang Rui

Phone: +86-10-51167367 Fax: +86-10-65711591

Email: wg@ctc.ac.cn, wr@ctc.ac.cn

80 - Shanghai Institute of Quality Inspection (SQI)

Shanghai Institute of Quality Inspection (SQI), No. 900 Jiangyue Road, Minhang District; Shanghai

Attn: Longmei Wang, Mr. Zhou Lei

Phone: +86.21.54336371 Fax:

Email: walm74@163.com, 438835686@qq.com

925 - Intertek Shenzhen Ltd Guangzhou Branch

Intertek Shenzhen Ltd Guangzhou Branch, Block E No 7-2 Guang Dong Software Science Park, Caipin Road, Guangzhou Science City; Guangzhou

Attn: Mr. Jeff Deng, Mr. Oliver Zhu, Ms. Juliet Guo

Phone: +86 20 82139782 Fax:

Email: jeff.jf.deng@intertek.com, oliver.zhu@intertek.com, juliet.guo@intertek.com